



MONROE & FRANKSON
HUDSON SALES and SERVICE
822 SO. SAN FERNANDO BLVD. - CH 6-1201
BURBANK

The New Hudson

NOW...YOU'RE FACE TO FACE WITH TOMORROW



Hudson presents a motor car triumph!

MOST PEOPLE are aware that a low-built motor car opens up opportunities for beautiful, long sweeping body lines. Most people are also aware of the fact that a truly low center of gravity provides an ability to "hug" the road under all conditions.

So you've seen cars with floors slanted, tops lowered until inside headroom and comfort threaten to become only fond memories . . . and with all this, a truly low center of gravity has seldom been achieved.

But now . . . Hudson designers and engineers, without compromise or face-lifting, meet the challenge of the low-built car with an entirely new kind of automobile!

Here is a motor car that harmonizes low, sweeping

exterior lines, with a roomy comfortable interior; a car with a new, lower center of gravity, a car only five feet from ground to top, yet a car with more than enough inside headroom for the tallest person, a car that maintains road clearance!

The new Hudson with its all-steel Monobilt body-and-frame is a car you step down into when entering, not up on. As shown in the cut-away view below, you ride not on top of a frame, but cradled inside of and completely encircled by heavy box-steel girders. And for even softer going, you also ride not only between axles, but completely ahead of the rear wheels!

The new Hudson is truly tomorrow's motor car today!

Hudson's new all-steel Monobilt body-and-frame is a sturdy, all-welded unit that provides rigidity and stability heretofore unheard of . . . a remarkably twist-free, rattle-free motor car!

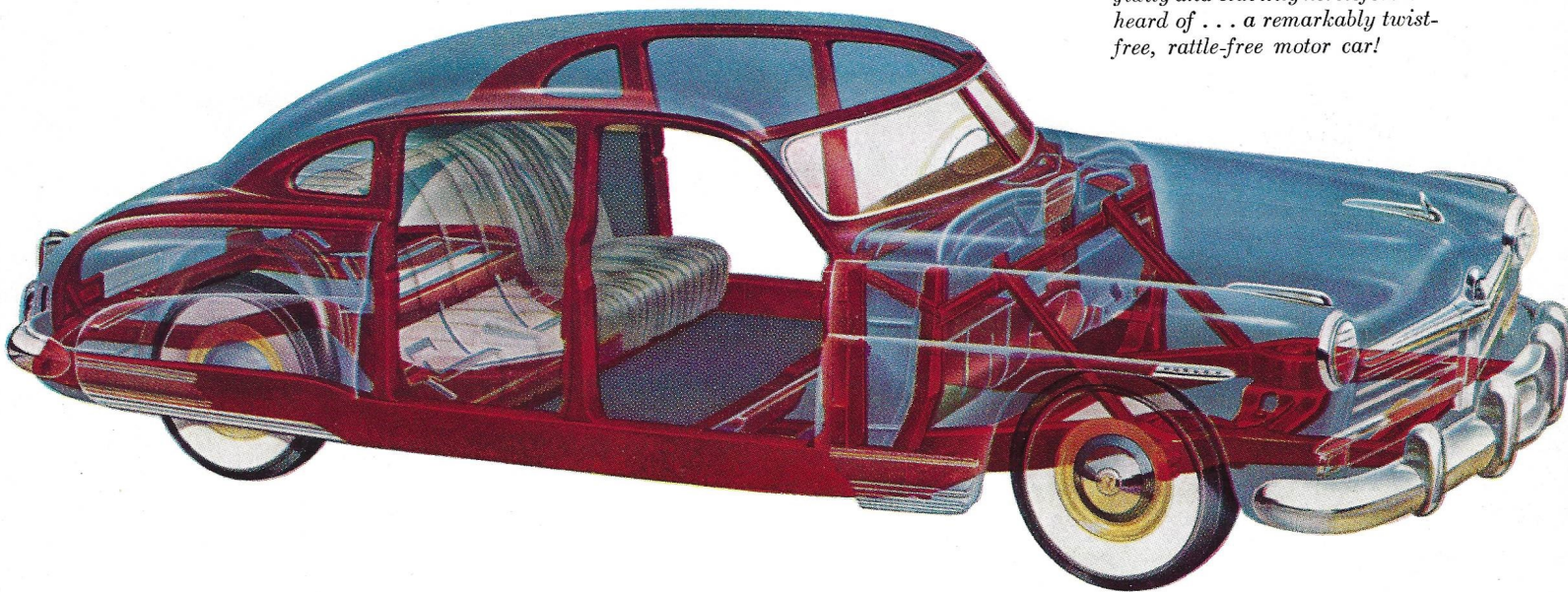

COPYRIGHT 1947, HUDSON MOTOR CAR COMPANY



Other Cars



Other Cars



New Hudson



New Hudson

You ride within the new Hudson box-steel frame, as shown at the lower left, not on top of a frame, as shown at the upper left; and ahead of rear axles and wheels, as shown in the lower right, not up over an axle, as shown in the upper right.

TRY SOME

Super-Driving

WITH HUDSON "DRIVE-MASTER"

Here's the easiest of all ways to drive . . . no clutch pushing, no gear shifting in forward speeds. You simply accelerate as long and as fast as you like in Hudson's silent pick-up gear, then lift your toe from the accelerator ever so slightly, and you're in high.

You change gears when you're ready . . . *you're* in command at all times, but Hudson Drive-Master does all the work!

When you want to stop, just use your brake pedal and you stop . . . there's no creeping! While the car is stopping, Drive-Master shifts down to pick-up gear automatically.



*Accelerate
as you like*

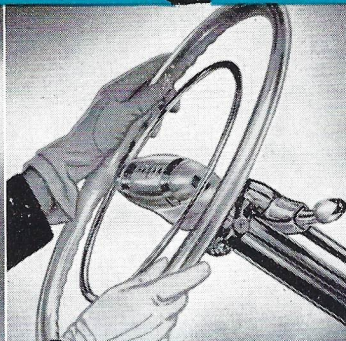

*Shift with a
lift of your toe*

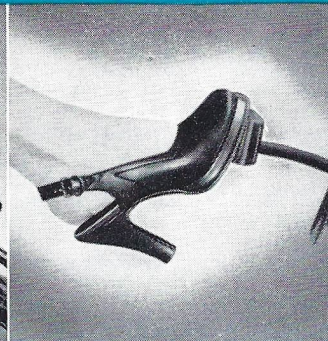

*To stop, use
only the brake pedal*

Your choice—three ways to drive. Hudson Drive-Master is equipped with instrument-panel control. You can have full Drive-Master super driving, or you can turn the control left for:

Vacumotive Drive—for manual shifting without clutch pushing. You shift gears effortlessly with Handy Shift at steering wheel; clutch is operated automatically. If you or some other member of your family prefer:

Conventional Drive—manual clutch and hand-shift driving—you simply turn instrument panel control button to center "Off" position, and car is ready for conventional driving.

With Drive-Master, which is exclusive with Hudson, you can "eat your cake and have it, too!"

Two great engines

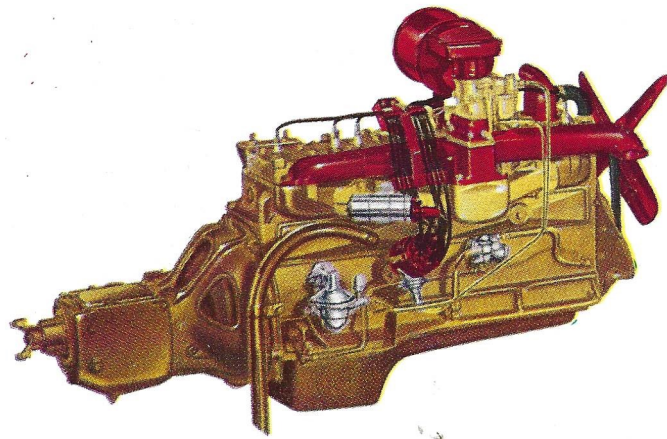

This improved Hudson Super-Eight engine is the answer for people who want action and power to spare, coupled with smooth performance. You'll get a thrill out of the way this great Super-Eight performs!

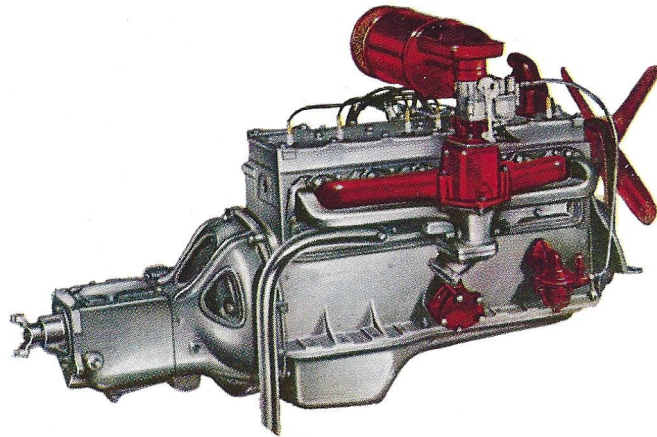

If you've ever longed for a six that can "show its heels" to any other six on the road—and to many eights, too!—here's your engine. This 121 h.p. new engine is the greatest Super-Six of them all—will out-perform anything of its kind!

Below: Close-up of the richest, roomiest, most comfortable motor-car rear compartment you can imagine. Chrome hand-holds on back of front seat in Commodore Sedan, plus robe cord and envelope-type pocket.

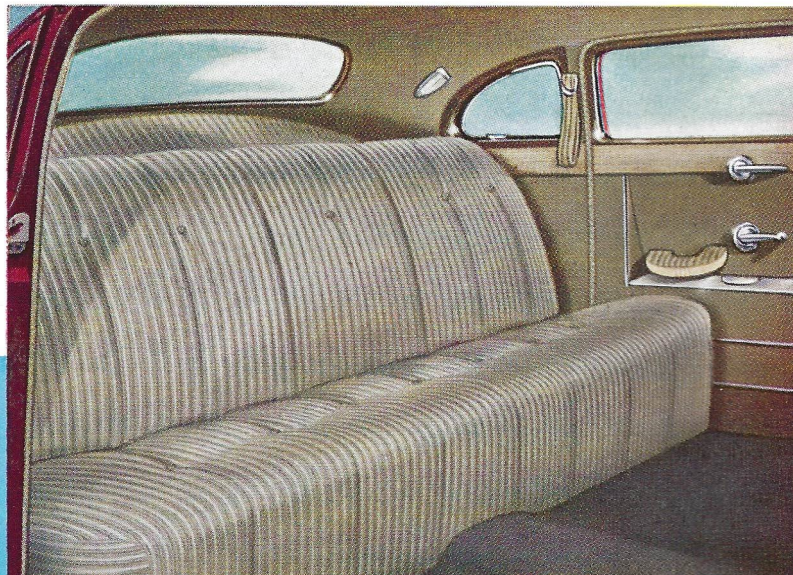

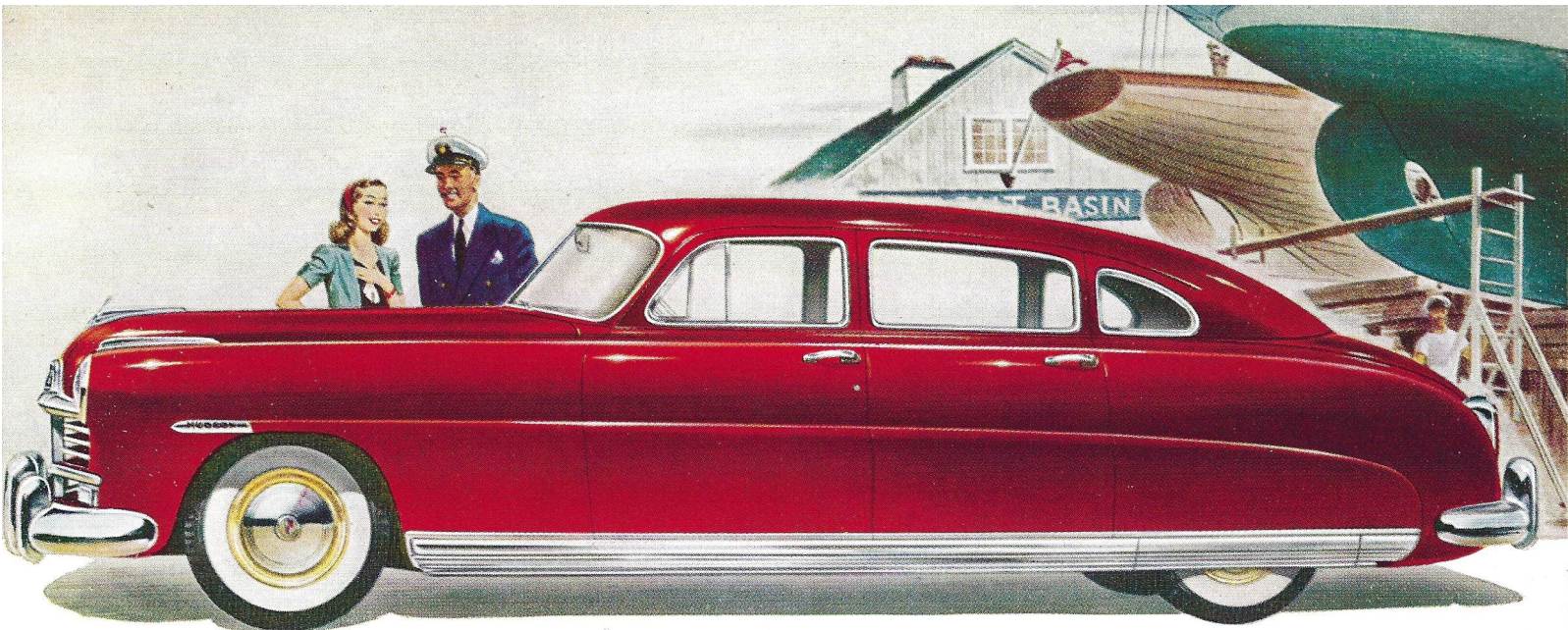

The Commodore Series FOUR-DOOR SEDAN

More than enough room for six passengers . . . 124-inch wheelbase . . . available with 121 h.p. new Super-Six or 128 h.p. improved Super-Eight engine. Choose from ten standard body colors. Two special body colors and five two-tone combinations, white sidewall tires, at small extra cost.

Two great series

The new Hudson in the distinguished Commodore Series and the brilliant Super Series is utterly beautiful—a thrilling symphony of rich color and clean, graceful lines that will fascinate you!

Notice the panel extending the entire length of this car, how it is set off with a bright metal base strip, how fenders have been absorbed into the body, and an embossed speed line is let into the side to give this new Hudson an appearance of forward motion, even when standing still.

This new kind of automobile *is* something to see, something to drive, *something to own!*

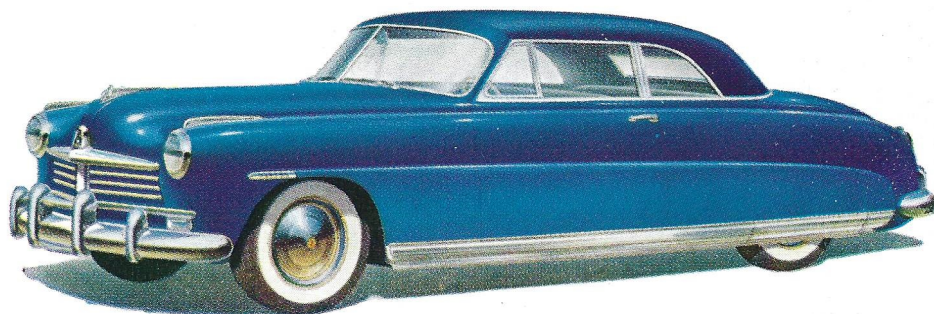

The Commodore Series CONVERTIBLE BROUGHAM

Six passengers . . . 124-inch wheelbase . . . 128 h.p. improved Super-Eight engine. Available in Super Series with 121 h.p. Super-Six engine. Three top colors to harmonize with same wide choice of body colors listed for other models. Choice of two colors in fabric or three colors in leather upholstery.

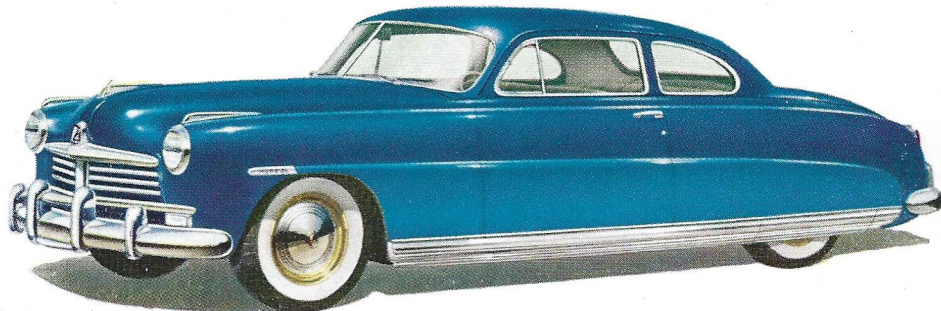

The Commodore Series CLUB COUPE

More than enough room for six passengers . . . 124-inch wheelbase . . . 121 h.p. new Super-Six or 128 h.p. improved Super-Eight engine. Choose from ten standard body colors. Two special body colors and five two-tone color combinations, white sidewall tires, at small extra cost.

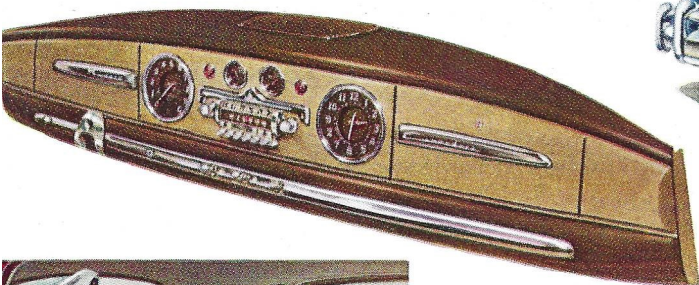

Commodore Series instrument panel has two harmonizing shades of grained walnut. Teleflash warning signals for oil pressure and generator charging rate. Dials and needle indicators all indirectly night-lighted to eliminate glare.

Left: Big "two-person" arm rest in down position, full 16 inches wide. Airfoam upholstered. Folds back into, and flush with, back cushion. Side arm rests recessed to give full use of spacious interiors. Plenty of head room, in these back seats, for a "six footer plus."

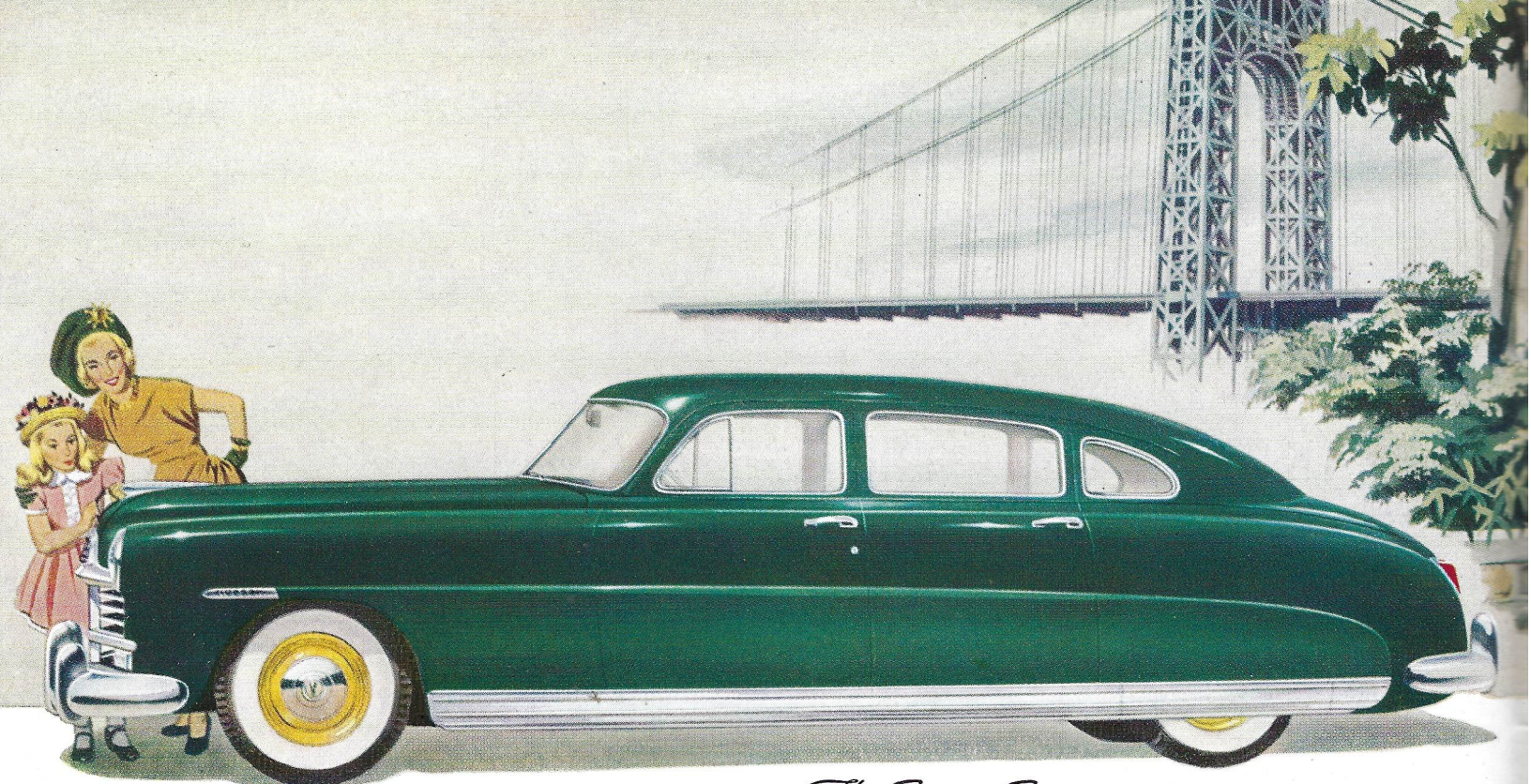

The Super Series FOUR-DOOR SEDAN

ARIDE in the new Hudson is a real treat! Hudson's new all-steel Monobilt body-and-frame cradles you so low, so snugly to the road, you get a feeling of serene, smooth going unlike anything you've known before—a new world of motoring pleasure!

Hudson's unique combination of soft-acting coil springs in front, and long, leaf springs in back, coupled with a new type of Super-Cushion, low-pressure tires, smooths out the roughest road. The slightest pressure on the accelerator brings forth a rush of engine power that is positively thrilling. This low-built motor car of tomorrow "hugs" the highway wherever you drive.

And when you realize you're riding in America's safest car made even safer, you'll begin to loll away the miles, for this is *Super Driving!*

More than enough room for six passengers . . . 124-inch wheelbase . . . 121 h.p. new Super-Six or 128 h.p. improved Super-Eight engine. Ten standard body colors. Two special body colors, five two-tone combinations, bumper guards, white sidewall tires, extra cost.

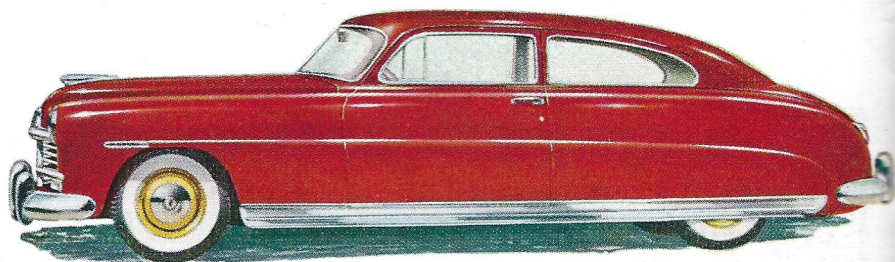

The Super Series TWO-DOOR BROUGHAM

More than enough room for six passengers . . . 124-inch wheelbase . . . 121 h.p. new Super-Six engine. Ten standard body colors. Two special body colors, five two-tone color combinations, bumper guards, white sidewall tires, at small extra cost.

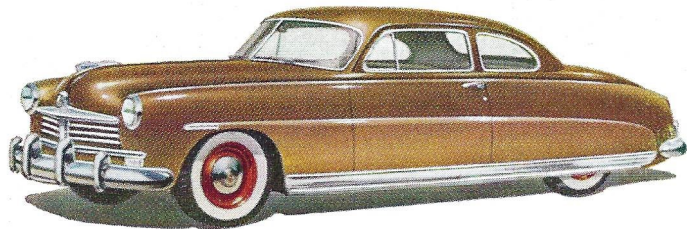

The Super Series CLUB COUPE

124-inch wheelbase . . . 121 h.p. new Super-Six or 128 h.p. improved Super-Eight engine. Ten standard body colors. Two special body colors, five two-tone combinations, bumper guards, white sidewall tires, extra cost. Available in three-passenger Business Coupe.

At right: Interior of Super Series line is beautifully finished and tailored. Dark walnut-color instrument panel and window garnish mouldings; striped Bedford Cord upholstery blended in tone with richly colored interior fabrics.

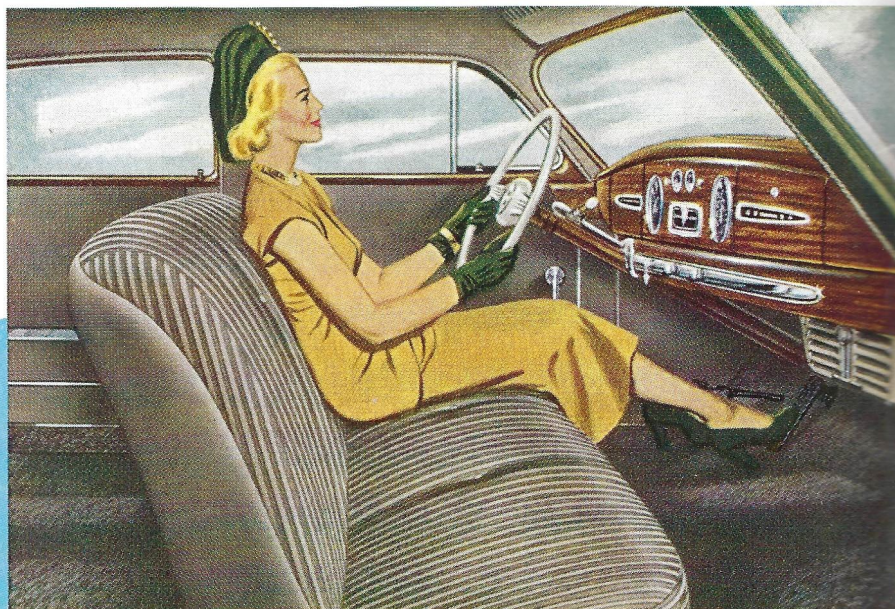

Here Today...



*the car you've been told
was years away!*

Where the motor car of tomorrow is being built now!

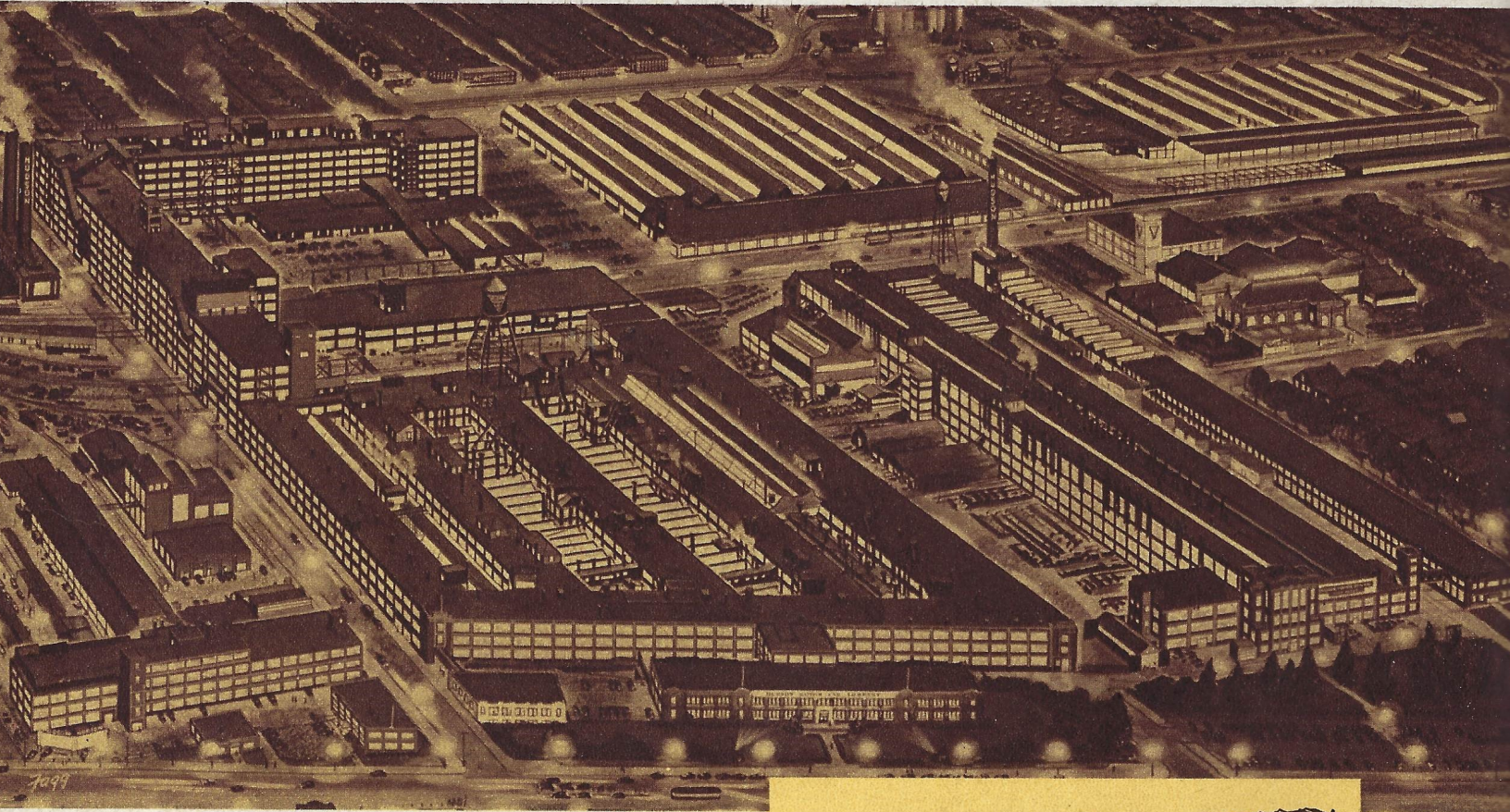

BEFORE you read about the thrilling features of the new Hudson described and illustrated in this booklet, it's worthwhile to know that Hudson *builds its own* motors, axles, Monobilt body-and-frames, clutches, controls, transmissions and other major components.

The composite view (above), painted from aerial photos, shows Hudson's more than three million square feet of factory space. This is where 16 million dollars have gone into installation of new production equipment and to develop entirely new production techniques for a new kind of car:

Upper right, building (A), Gear, axle manufacturing, assembly; (B), Service parts assembly, boxing, shipping, export shipping; (C), Metal heat treating.

Lower right, building (D), Monobilt body-and-frame, fender and sheet metal manufacturing, finishing, painting; (E), Medical center.

Center group, building (F), Assembly and production line for rear axle, springs, shock absorbers, stabilizer bar, propeller shafts, gas tank, muffler, brake lines;

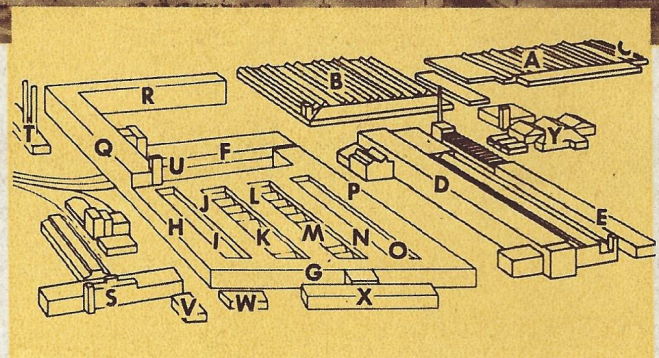

(G), Super-Six and Super-Eight engine manufacturing, assembly, testing; (H through P), Machine shops, metal heat treating; (J,L,N), Cushion, upholstery fabrication; (P—first and second floors), Manufacturing, assembly of clutches, transmissions; (Q), Production line for front end, including wheels, tires, engine, radiator core, grille, hood; (F,P,G,H,Q and R), Mile-long assembly line; (R), Final inspection, tune up, material storage. Lower left, (S), Research, Experimental Laboratories, Engineering Buildings; (T), Power plants; (U), Direct rail receiving, shipping; (V), Personnel building; (W), Medical Center, Hospital; (X), General and Executive Offices; upper right, (Y), Hudson Motors, Ltd., London, England.

New motoring thrills for you in a new kind of a car

Never before have you ridden in a car like this! Hudson designers and engineers felt that the time had arrived for a fundamental change in automobile design.

Here is an entirely new kind of car! The new Hudson is only five feet from top to road, with a new lower center of gravity, yet it maintains road clearance.

Hudson's new all-steel Monobilt body-and-frame, shown on this page, makes all this possible. Body and frame are combined in a single, sturdy all-welded unit—with rigidity and stability—freedom from squeaks and rattles—unheard of heretofore.

You step *down* into the new Hudson when entering, not up on it. You sit on the roomiest seats ever built into any American automobile. You ride encircled by heavy, box-steel girders—not only between axles but entirely ahead of the rear wheels! By lowering seats and floor with the new lower top (instead of lowering the top down on the seats) Hudson gives you more headroom, front and rear—room aplenty for the tallest member of your family.

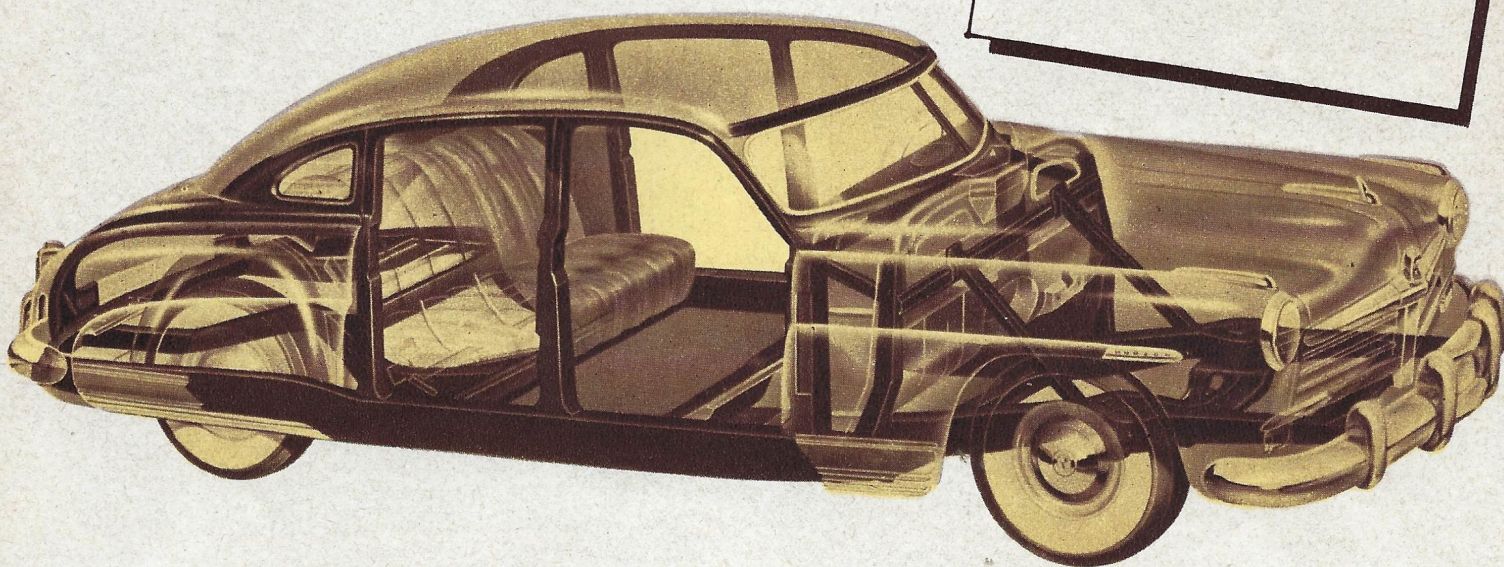
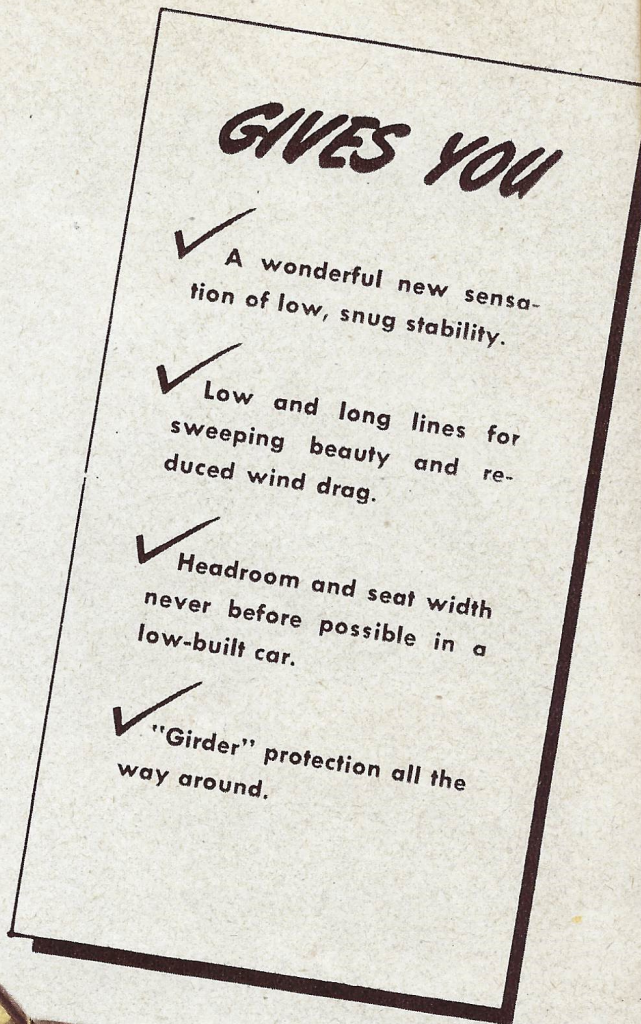

This is Hudson's new, exclusive, all-steel Monobilt body-and-frame in phantom view. Notice the floor, shown in medium dark brown, and how you step down into this new kind of car, how the structural members, shown in darkest brown, completely encircle the passenger area, with the rear seat completely ahead of the rear wheels. These members are solidly welded into a single rigid unit with roof, floor and body panels, which are partially shown in phantom.

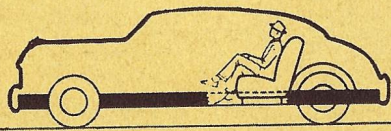
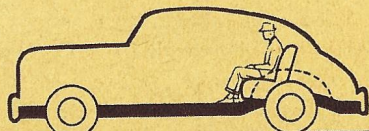

Conventional cars

Riding over axles and above frame, reduced headroom and comfort.

Hudson

Riding ahead of rear axle and even ahead of rear wheels, inside frame, spacious headroom, new comfort.

Wider inside than it is high!

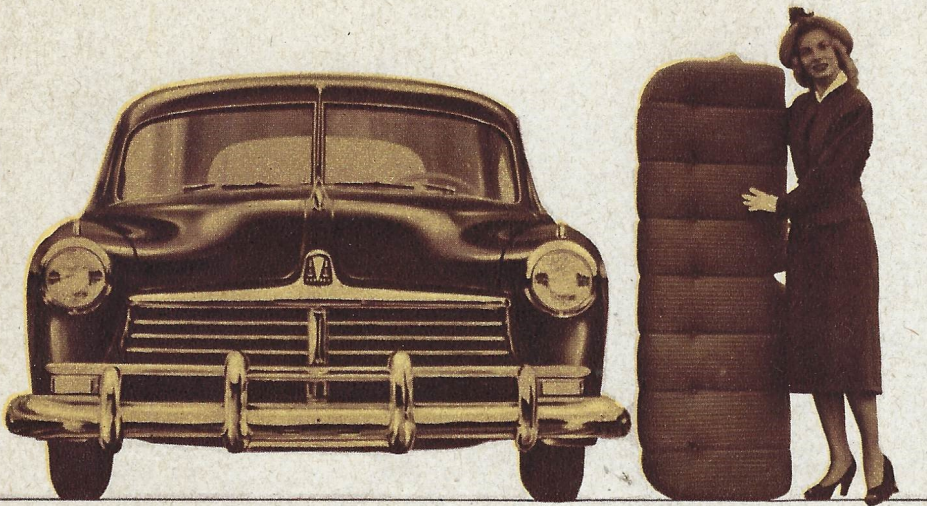

Step out in a car that's "low, wide and handsome" . . . a new kind of car that matches advanced engineering with a new kind of beauty. The new Hudson is actually wider—*inside*—than it is high! A full 66 inches of usable inside width!

Completely new techniques of design and construction give you a bigger, roomier car—and the lowest, sleekest automotive lines you'll see on any road.

Headroom...

. . . to let you sit up!

The new Hudson is only 5 feet high, but you'll find more headroom than you ever dreamed possible in a low car! A "six-footer" in a sombrero can sit erect in the rear seat. This car is built low from the inside out, seats and floor are lowered to harmonize with the new lower top—yet it maintains road clearance.



Step down into a Hudson . . . not up on it

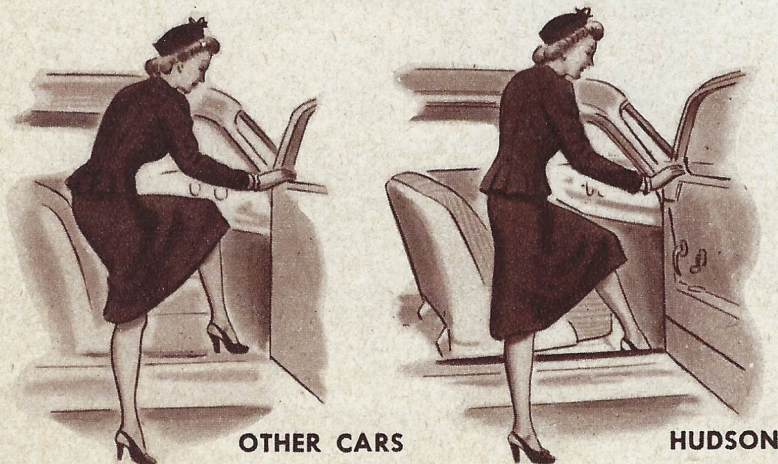

Step *down* as you enter your new Hudson . . . the easiest car to get in and out of you can imagine. Entering is an easy movement . . . effortless. And seating yourself is like relaxing on a lounge at home! Low, snug seating creates a feeling of security and stability.

Note, in the sketches at left, the more natural position you maintain as you enter a Hudson. The lower floor and greater inside height enable you to enter without "jack-knifing" your body.



Room...

and to spare!

Like lots of room for comfort? Then, this new Hudson is for you. Hudson's new design provides more usable space bumper to bumper and side to side. Deep, wide seats invite you to "spread out." With 63 to 64 inches of seat space, Hudson provides generous room for *every* passenger. Door and window controls and arm rests are recessed into door—full seat width is usable.

Luxury arm rest 16 inches wide

All the comfort of an overstuffed easy chair with this luxurious "two-person" arm rest that measures full 16 inches across (folds back into and flush with back cushion). Test the cloud-like Airfoam cushioning—it's soft, resilient, outwears ordinary cushions. Standard in the Commodore four-door Sedan and Commodore Club Coupe.



Leg room to relax

Stretch out . . . take it easy . . . no matter where you sit in a Hudson! Plenty of leg room—and foot room, too. You can move around and change position with ease . . . no need to "sit tight" in a Hudson. Proper seat height gives adequate support for leg comfort. Generous sized inset under the front seat-back prevents cramping. Note the exceptional room for leg movement in the Club Coupe, shown at left. In Club Coupes and Broughams front seat-back tilts forward and inward to provide ready access to back seat.

TELEFLASH SIGNALS

No need to check repeatedly on ammeter or oil pressure gauges. Teleflash signals flash "red" to warn you automatically if attention is needed.

LARGE PACKAGE COMPARTMENT IN INSTRUMENT PANEL

You'll enjoy the convenience of this wide and deep compartment with far more storage space than in most cars.



Commodore Series Instrument Panel

STEERING WHEEL

Extra large, with sparkling plastic rim, chrome horn ring standard on Commodore series cars.

RADIO PANEL

Styled to harmonize with instrument panel, convenient push-button controls, speaker mounted with louvers on top of instrument panel to improve back seat reception.

HANDY SHIFT

Conveniently located, attractive plastic handle, finger-tip operation.

CLOCK

Large round dial you can read easily. Clock is 30-hour type in Super series, electric in Commodore series.

CIGARETTE LIGHTER

Automatic type, "pops" out when red hot, located in center of instrument panel on Commodore Series, convenient for all.

ILLUMINATED IGNITION KEYWAY

Diffused, spot lighting illuminates keyway when light switch is in parking light position.

FOOT-OPERATED HEADLIGHT BEAM DEFLECTOR

By pressing convenient floor button with left foot, you raise headlight beam for country driving.

**CONVENIENCE
ALL AROUND**



LUGGAGE SPACE GALORE

Rear view of coupe shows space with 15 different bags and suitcases packed in. All Hudson models have exceptionally large luggage compartments. Illuminated by tail light bulbs.



REAR DOME LIGHT

Two brilliant dome lights in rear of all Commodore models.

EXTRA LARGE PACKAGE SHELF

Loads of room on shelf back of rear seat to store small packages on those shopping tours.

EASY-TO-READ DIALS ON INSTRUMENT PANEL

Large round dials you can read at a glance. Figures of special extruded light-carrying plastic and red instrument needles glow at night without glare.



Super Series Instrument Panel

HEADLIGHT BEAM INDICATOR

Triangle in speedometer lights up in red when bright lights are on.

STARTER PUSH BUTTON

Handily located at the left side of the instrument panel, finger-tip operated.

SAFETY HOOD RELEASE

Automatic hood catch locks when hood is closed, made doubly secure by positive locking lever in front compartment. When car is locked, no one can tamper with wires, battery or engine.



DOOR PANEL RECESS

Door controls and arm rests are recessed into door panel giving more room, greater safety. Doors are wide for easy entrance and exit. Ash receivers at each end of front and rear seats.

AND COMFORT YOU

Comfort and convenience take on new meanings when you step into this handsome Hudson. At every hand... on every side... features that say "Great car!"

CUSHION-ACTION DOOR LATCHES

Doors close tightly with light pressure, no need to slam. Cannot jar open.

OUTSIDE DOOR HANDLES

Newly designed non-rotating handles. Latch is trigger-operated for easy, positive action.

HAND HOLD ON REAR OF FRONT SEAT

On all Commodore Sedans a convenient chrome hand hold is set at either end of robe cord.

MAGAZINE POCKET

A handy, large-sized pocket for magazines, maps, etc., is on back of front seat in sedan models.

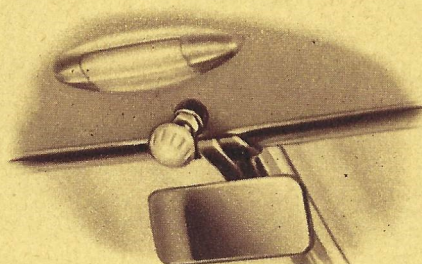

FRONT DOME LIGHT

All models have bright front dome light, for maximum interior illumination.

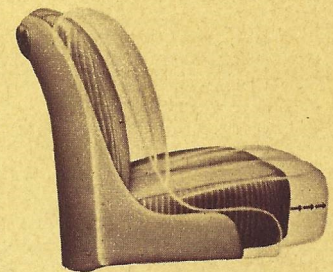

ADJUSTABLE FRONT SEAT

All front seats can be moved forward or backward four inches to accommodate persons of various heights. Seat raises as it moves forward.

HOW TO DRIVE ALL DAY IN WITH Hudson

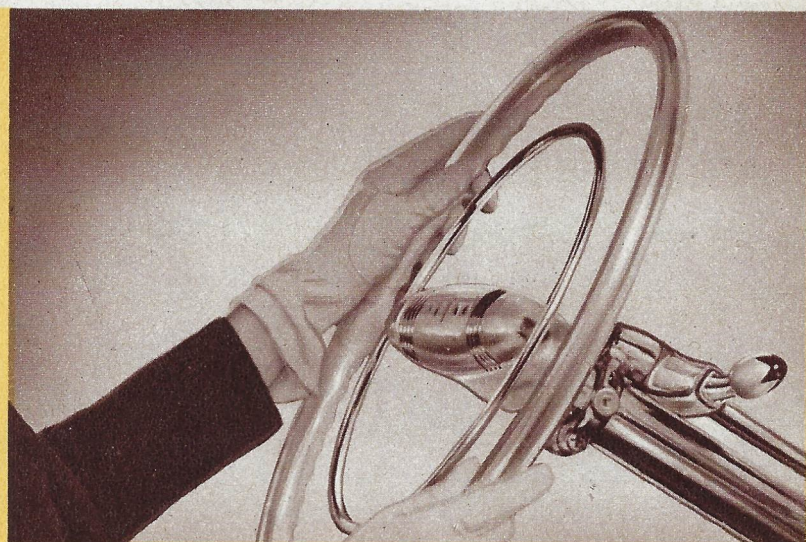

1 PRESS ACCELERATOR
TO GO FORWARD

2 STEER

GET SET for astonishingly pleasant driving when you try Hudson's Drive-Master, available on all models at small extra cost. This is the easiest of all ways to drive—there's nothing new to learn. On all normal straight-ahead driving you never need to touch either clutch or gear shift. When using Drive-Master, just put the Handy Shift lever in the "high" position and you're ready to drive all day in three easy motions.

Just press the accelerator. You're moving ahead in Hudson's silent pick-up gear—accelerate as long and fast as you like. Then lift your toe ever so slightly, and you're in high. When it's time to stop, push the brake pedal. While you're coming to a stop, Drive-Master automatically shifts down to pick-up gear. There's no creeping—your car is motionless, but ready automatically to move ahead again when you touch the accelerator with your toe.

Saves 85% of Your Driving Motions!

In a typical everyday drive, as shown in sketch at right, you make 51 motions with conventional drive, but *only 7 with Drive-Master!*



CONTROL ON
INSTRUMENT PANEL

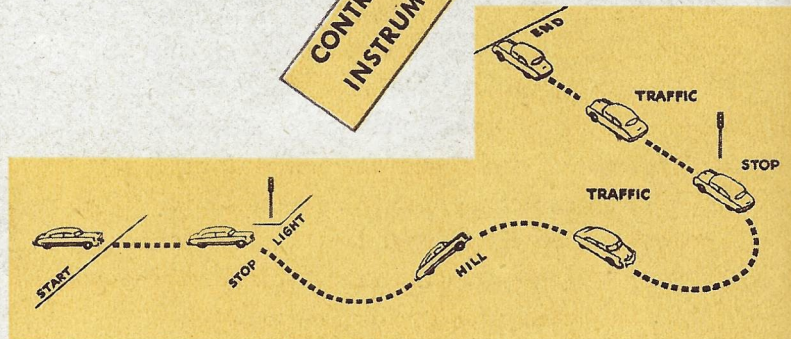

ASK YOUR HUDSON DEALER FOR A DEMONSTRATION

ONLY 3 EASY MOTIONS...

Drive-Master



3 PRESS BRAKE TO STOP

Only Hudson gives you this flexibility

Hudson's Drive-Master gives you greater adaptability to a wide range of driving conditions than any other so-called automatic transmission. The selector switch on the instrument panel, as shown in illustration at left, offers you three methods of driving . . . turn to right for Drive-Master, with no forward-speed shifting or clutch pushing . . . turn to left for Vacumotive drive, with manual shifting to any gear without clutch pushing . . . Conventional drive —if some members of your family prefer conventional driving, the switch can be turned to center "off" position to provide for this method.

**NO
CLUTCH PUSHING!
NO
GEAR SHIFTING!**

EXCLUSIVE DRIVE-MASTER ADVANTAGES

- **FASTER ACCELERATION . . .**
When you want to get out in front, stay in Hudson's pick-up gear as long as you want . . . step up to any speed. Then lift your toe ever so slightly and you float along in high. You're in control at all times, but Drive-Master does all the work!
- **NO "CREEP" WHEN YOU STOP . . .**
Come to a stop with Drive-Master and you stop —positively. There's no tendency for the car to edge ahead. Touch the accelerator and you are away in a flash.
- **ECONOMY IN OPERATION . . .**
Hudson Drive-Master does not require frequent refilling with expensive special fluids.
- **DEPENDABLE DESIGN . . .**
Tested and proved in billions of miles of driving by thousands of Hudson owners in all kinds of driving conditions. Unit located under hood for convenient lubrication or adjustment.

OF THIS "EASIEST OF ALL WAYS TO DRIVE."

A CAR FULL OF FRESH SUMMER

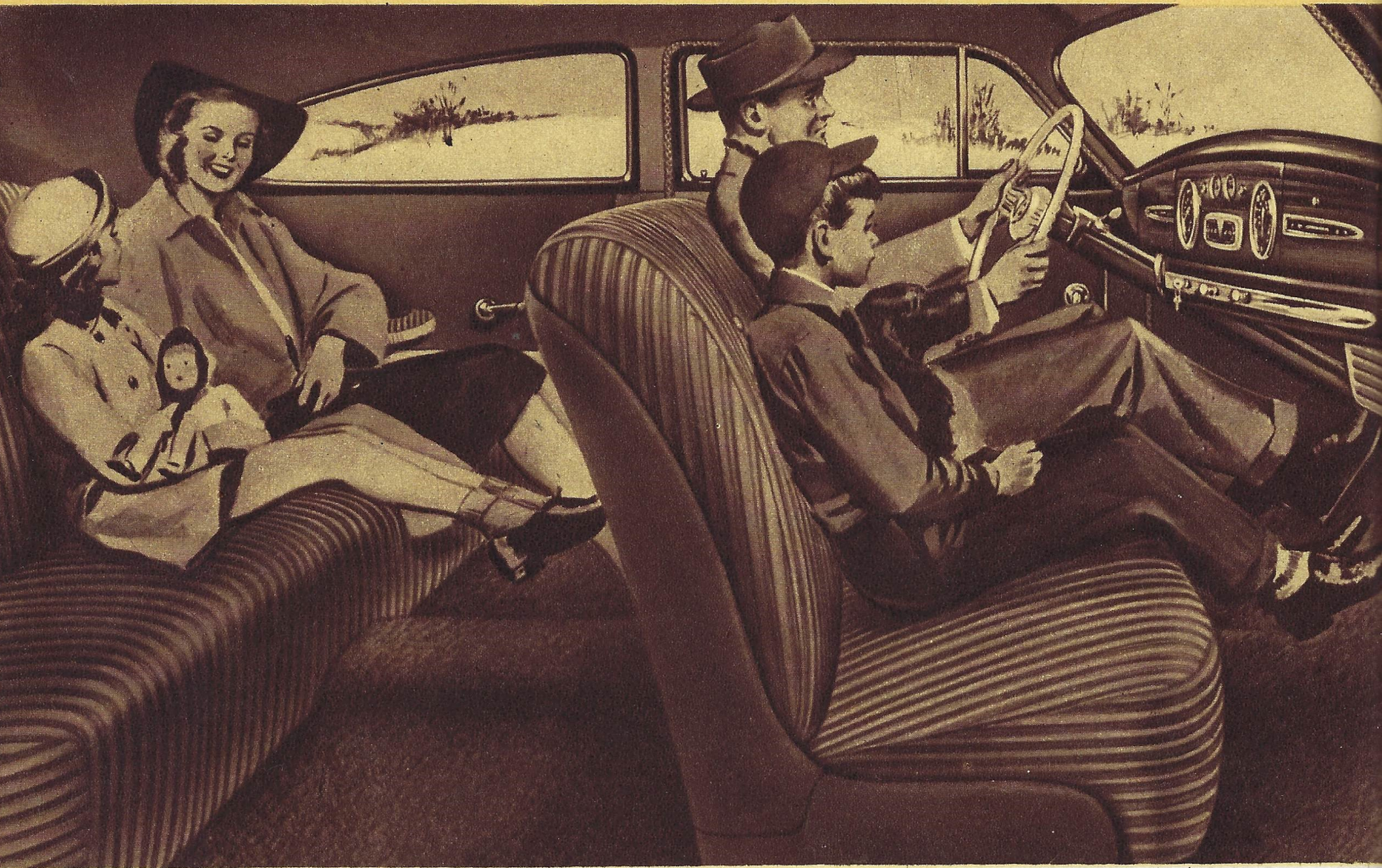

NEW PLEASURE IN SUMMER DRIVING!



ON RAINY DAYS

Down comes the rain, but your Hudson's windows are found to be unusually free from fog and steam. With any convenient window or ventilating wing opened ever so slightly, and with Weather-Control at work, you still enjoy abundant fresh air.

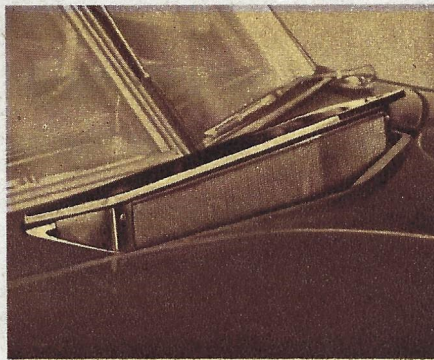

OPEN COWL VENTILATOR SHEDS RAIN

Only air gets past a Hudson cowl ventilator. Rain is trapped to drain off, dust and dirt are filtered out and insects are blocked by a sturdy cowl screen.



NO DRAFTS

Car movement brings in abundant fresh air through the cowl ventilator. The Hudson Weather-Control system—combined with ventilating wings—eliminates drafts around your neck and ankles.

AIR...ALL WINTER LONG!

HUDSON WEATHER-CONTROL

Take winter's worst with a smile . . . in your new Hudson. Hudson Weather-Control, available for all models at slight extra cost, takes the sting from the north wind, the bite from a blizzard.

Your car is filled with warm *fresh* conditioned air from the open cowl ventilator—gently pressure circulated for the comfort of every passenger. You select the temperature you want. Highly efficient defrosters speedily melt away dangerous sleet, snow and ice.

Hudson Weather-Control actually runs on air! For all normal driving, air is forced in by forward movement of car. A powerful blower fan is provided for use when car is slowed down or stopped. Hudson Weather-Control is more than just a heater—it filters, warms and circulates fresh air from the open cowl ventilator throughout the interior, *replacing* stale air and smoke. Hudson Weather-Control does not re-heat and re-circulate "dead," stale inside air.

Complete circulation is further achieved by opening rear-quarter windows, swivel-opening wing type with friction latch in Sedans . . . crank-operated type in Broughams and Club Coupes.

- WARM, FRESH AIR
- YOU SELECT THE TEMPERATURE
- NO FROST ON WINDOWS
- NO SMOKE
- NO DRAFTS

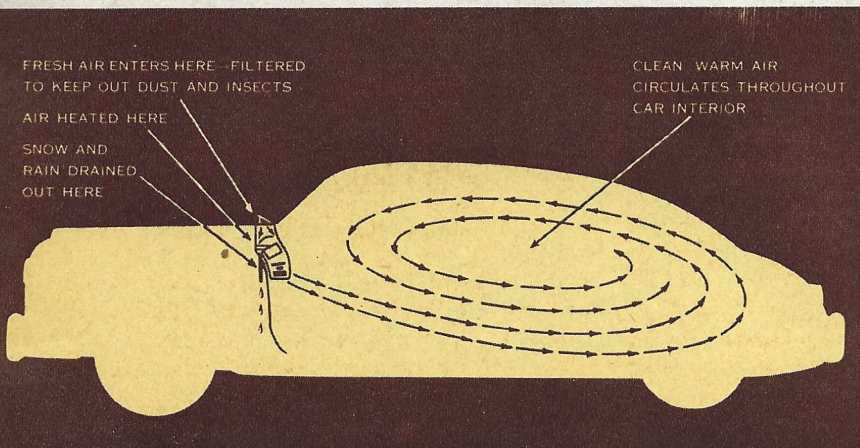

Hudson Weather-Control is located for convenience and efficiency. Attractive design is in keeping with Hudson's smart interior. Fingertip controls for heat regulation and fan.

Forward motion of car forces abundant fresh air through the cowl ventilator for gentle pressure circulation to both front and rear compartments. For still greater comfort, every Hudson is insulated against heat and cold, sound-proofed and moisture-proofed.

A "HONEY" TO HANDLE...

TRUE CENTER-POINT STEERING TAKES THE "FIGHT" OUT OF THE TOUGHEST ROAD

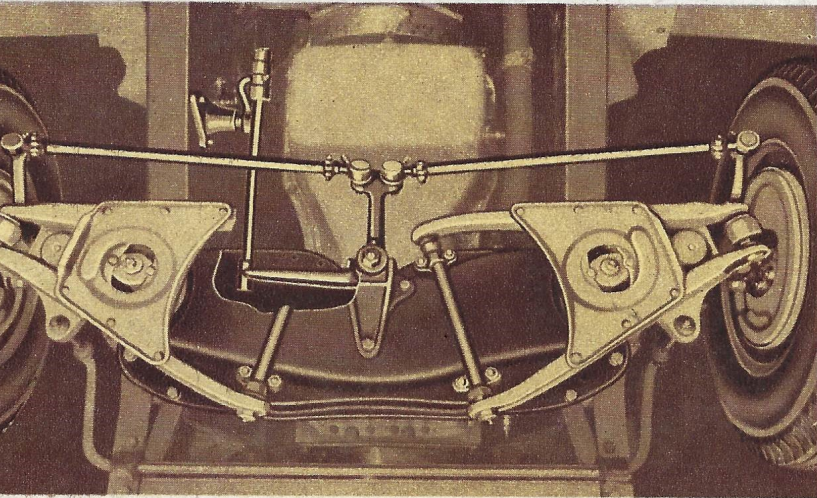

Take the sharpest turn . . . easily, sweetly in a new Hudson. The steering system is perfectly balanced to end "roaming" and "wheel fighting!" Hudson's Center-Point steering operates from the exact center of the car, affects both front wheels directly, equally . . . is simpler and more accurate than "off-center" steering.

BIG STEERING WHEEL AND EASY TURNING RATIO

A big, beautiful, 17-inch steering wheel in all Super models, and an even bigger 18-inch wheel in Commodore models, helps give "feather touch" steering. A ratio of 20.4 to 1 gives you maximum steering ease through minimum wheel turn . . . lets you hold your Hudson on a course with ease.

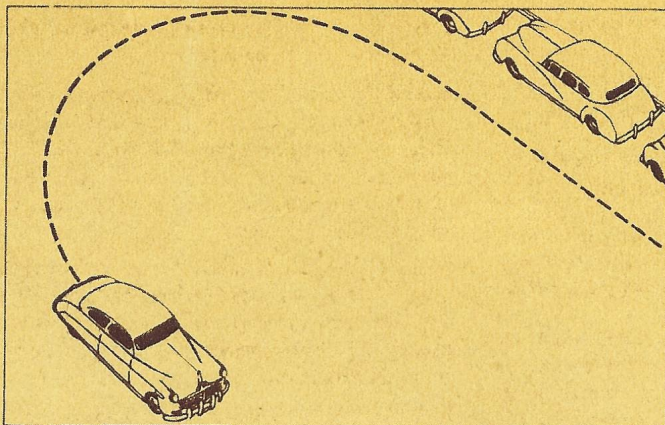

TURNS IN SHORT RADIUS

You can easily turn this new Hudson completely around without backing . . . or swing "neatly" into narrow drives. Turning radius is only 20 feet—despite a long, 124-inch wheel base.

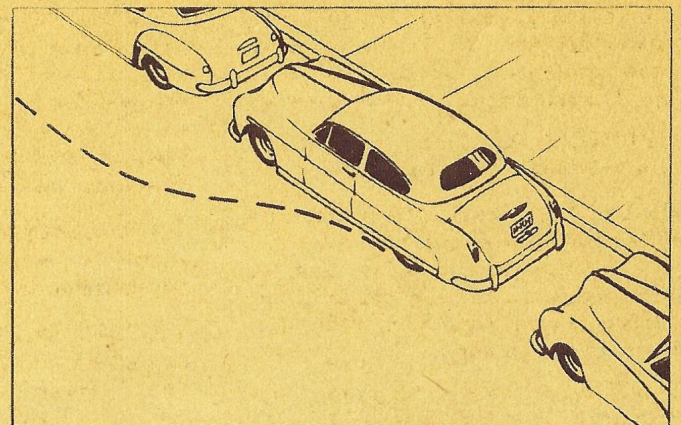

EASY TO PARK

Swing a new Hudson into a tight parking space . . . more easily than with many smaller cars. Short turning radius, easy steering and unhampered visibility make parking a breeze, even in cramped quarters.

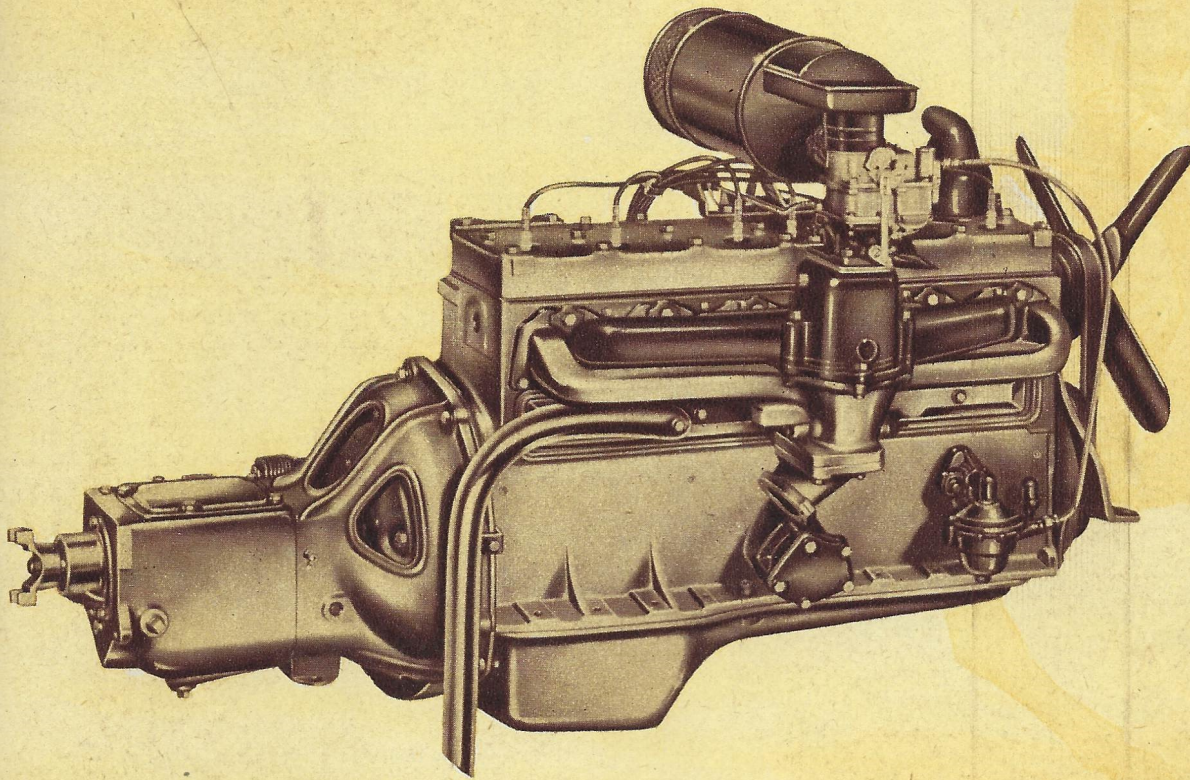

NEW HUDSON SUPER-SIX ENGINE

Rarin' to go! If you've ever longed for a six that can "show its heels" to any other six on the road—and to many eights, too!—here's your engine.

Specifications

6-CYLINDER, L-HEAD, 121 horsepower at 4000 r.p.m.; Compression ratio, 6.50 to 1; Bore, 3 $\frac{3}{16}$; Stroke, 4 $\frac{3}{8}$; Displacement, 262 cubic inches.

CYLINDER HEAD: High turbulence type for better fuel combustion.

CRANKSHAFT: Forged in position, fully compensated and equipped with rubber-insulated vibration damper, balanced at rest and in motion. Four precision type, steel-backed, babbitt-lined main bearings.

PISTONS: T-slot, cam ground, aluminum alloy, fitted with four pinned, plated piston rings.

CONNECTING RODS: Drop-forged, high manganese alloy, with replaceable, steel-backed, babbitt-lined precision type bearings. Rifle-drilled for lubrication to piston pin bearing.

CAMSHAFT: Nickel-chrome-molybdenum-iron alloy . . . for quiet operation . . . with angular ground cams for positive rotation of tappet. Heat treated for extreme hardness. Phosphate coated for better lubrication. Bearings pressure lubricated.

TAPPETS: Improved, rotating mushroom type with special self-locking adjusting screw. Pressure lubricated.

VALVES: Special alloy. Installed at angle for faster intake and exhaust flow. Grooved for conical spring seat retainer. Valve seats integral with cylinder block, cooled around entire surfaces. Exhaust valves are of high nickel-chrome alloy.

CYLINDER BLOCK: High chrome alloy, entire block as hard as valve seat inserts used in many cars. Water

jackets full length of cylinders and all around each cylinder.

CARBURETION: With more direct passage of fuel through radial manifold to combustion chamber. Dual down-draft type. Automatic choke. Climatic control. Anti-percolator valve. Air cleaner.

LUBRICATION: Full pressure lubrication to 41 points. Oil refill capacity 7 quarts. Float type oil intake draws clean oil from point just below top level in oil pan.

COOLING SYSTEM: Cellular-tubular type radiator, improved ball bearing type six-blade, self-sealing pressure pump with large impeller. Capacity 17 quarts. Thermostatically controlled by-pass for quick engine warm-up. Fan blades acoustically positioned to minimize sound.

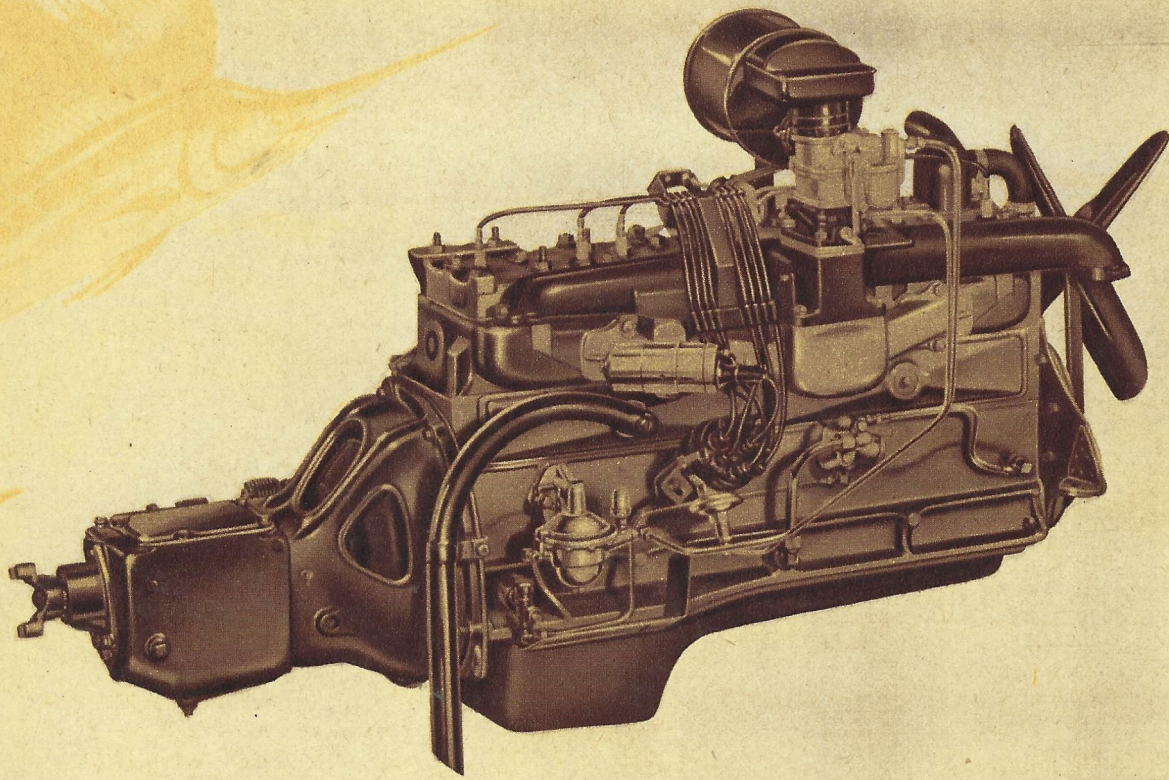

IMPROVED HUDSON SUPER-EIGHT ENGINE

This improved Hudson Super-Eight engine is the answer for people who want action and to spare, coupled with the smooth performance that only an eight can give, and with unusual economy.

Specifications

8-CYLINDER, L-HEAD, 128 horsepower, at 4200 r.p.m.; Compression ratio, 6.50 to 1; Bore, 3 inches; Stroke, 4½ inches; Piston displacement, 254 cubic inches.

CYLINDER HEAD: High turbulence type for better combustion.

CRANKSHAFT: Drop-forged, fully compensated and equipped with rubber-insulated damper, balanced at rest and in motion; five long-wearing, bronze-backed main bearings.

PISTONS: T-slot, cam ground, aluminum alloy, fitted with four pinned, plated piston rings.

CONNECTING RODS: Drop-forged, high manganese alloy for greater strength, dowel-fitted caps assure perfect alignment. Bearings with cen-

trifugally installed babbitt metal.

CAMSHAFT: Nickel-chrome-molybdenum-iron alloy . . . for quiet operation . . . heat treated for maximum hardness, specially treated for smooth finish. Large babbitt bearings.

TAPPETS: Exclusive roller cam design. Rotating cam lobe maintains constant contact, requires less adjustment, wears longer.

VALVES: Special alloy steel. Exhaust valves have high chrome content to resist high temperatures.

CYLINDER BLOCK: Super-hard chrome alloy. Provides wear resisting cylinder bores, eliminates need for special valve seat inserts. Entire block is as hard as valve seat inserts used by many manufacturers.

CARBURETION: Down-draft type. Dual flow to combustion chambers for more complete combustion. Radial intake manifold provides direct, free flow passages for fuel mixture. Automatic choke. Climatic control. Anti-percolator valve. Air cleaner.

LUBRICATION: Exclusive Duo-Flo supplies oil in direct ratio to engine speed. Lubricates every part at first turn of crankshaft. Float type oil intake draws clean oil from point just below surface of oil in pan.

COOLING SYSTEM: Cellular-tubular type radiator. Improved ball-bearing type six-blade, self-sealing pump with large impeller. Capacity 18 quarts. Thermostatically controlled by-pass for quick engine warm-up. Fan blades acoustically positioned to minimize sound.

TOP-NOTCH PERFORMANCE AT YOUR COMMAND

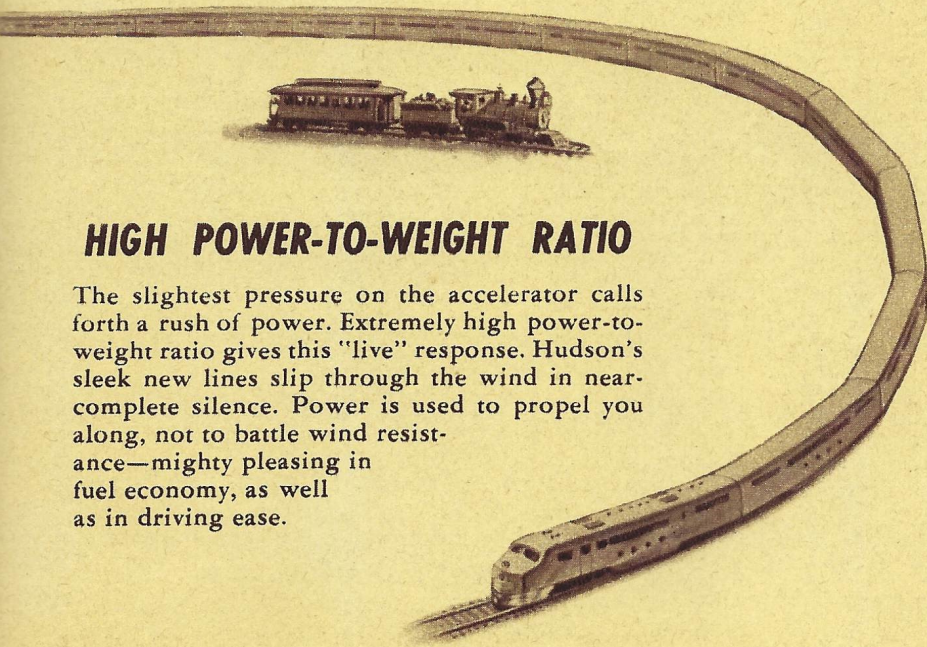

HIGH POWER-TO-WEIGHT RATIO

The slightest pressure on the accelerator calls forth a rush of power. Extremely high power-to-weight ratio gives this "live" response. Hudson's sleek new lines slip through the wind in near-complete silence. Power is used to propel you along, not to battle wind resistance—mighty pleasing in fuel economy, as well as in driving ease.

HIGH-COMPRESSION ENGINES

Hudson new Super-Six and improved Super-Eight engines are of the high compression type... greater compression of the fuel-air mixture results in more powerful explosions . . . greater engine output. Compression ratio for both engines is 6.5 to 1.

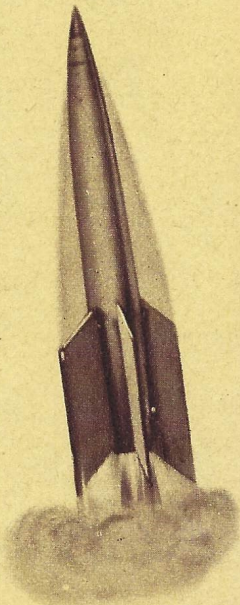

GET AWAY SMOOTHLY *with* FLUID CUSHIONED CLUTCH!

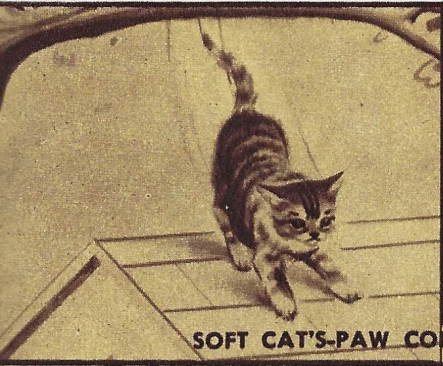

SOFT CAT'S-PAW CONTACT WITH CORK TIPS

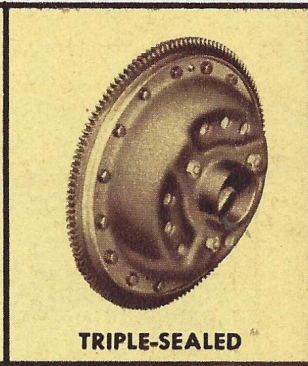
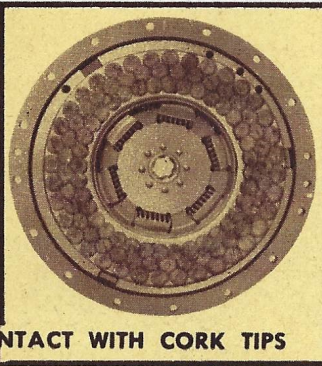

TRIPLE-SEALED

Whether you're using conventional drive or Drive-Master, you can always count on smooth clutch engagement. Exclusive Hudson clutch operates at all times in a cushion of oil. Special heat-treated cork friction surfaces give soft cat's-paw action . . . sure gripping with no metal-to-metal contact. Triple sealed against dirt and weather. Smoother acting and longer lived than dry-plate clutches. Costs more to build . . . less for you to operate.

OVERDRIVE SAVES YOU MONEY



Hudson Overdrive, available on all models at slight extra cost, lets you drive with your engine running only 72% as fast as it normally would! You get smoother, quieter operation and an immediate reduction in fuel consumption. You can take advantage of Overdrive savings at speeds even as low as 20 miles per hour.

SPECIAL UNDER-BODY JACK PADS FOR TIRE-CHANGING CONVENIENCE

Fast, safe wheel changing in your new Hudson. Four jack pads are integral part of Monobilt body-and-frame. Jack fits into pad for non-slip safety—easy location without groping. Rear wheel shield has one-point locking control for quick removal and replacement. Ample room to slip rear wheel from behind protecting body-frame girder.

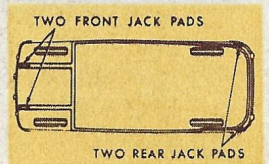

TWO FRONT JACK PADS

TWO REAR JACK PADS

AMERICA'S SAFEST

HUDSON TRIPLE-SAFE BRAKES

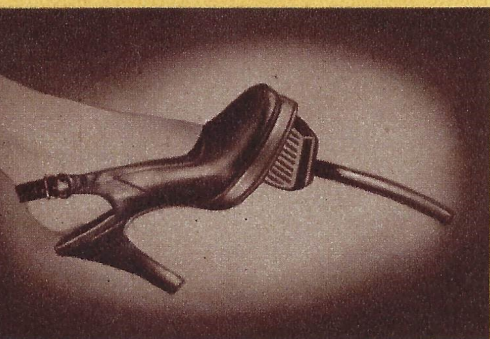

HYDRAULIC

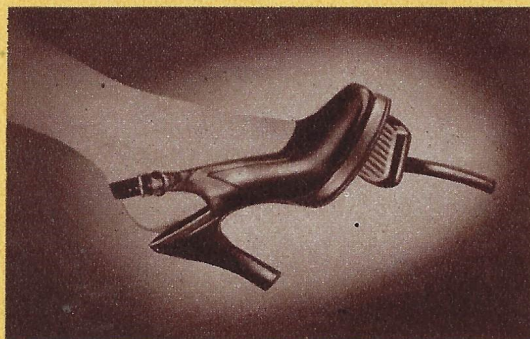

MECHANICAL RESERVE



HAND BRAKE

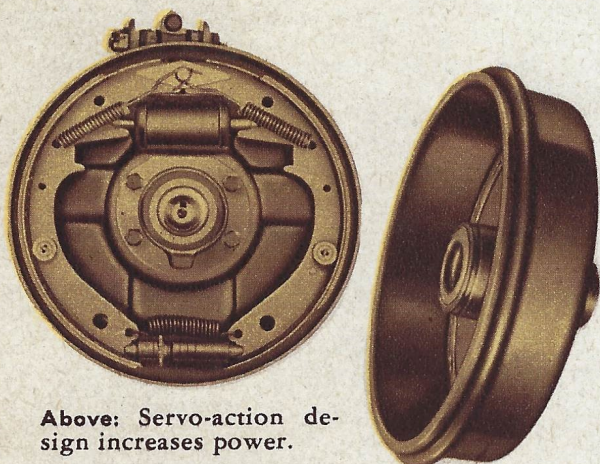

Above: Servo-action design increases power.

Right: Rigid steel drum with cast-iron facing.

As you bring a Hudson to a smooth stop, you'll enjoy a special tingle of authority, for Hudson—and Hudson alone—offers the safety of *three* methods of brake application! For general use Hudson provides powerful hydraulic brakes—proportioned front and rear to car weight distribution. "Servo-action" design of brakes converts the forward rotation of the wheels to extra braking pressure.

For even greater safety, Hudson gives you a reserve mechanical

brake system, ready to take over automatically from the same brake pedal if hydraulic pressure should fail, as it can in any car due to accident or service neglect. Mechanical brakes start to work when brake pedal reaches a point a few inches above floor board. You just push down harder on the same pedal, as you instinctively would.

Control of positive-action parking brake is below instrument panel, only a few inches from your left hand. Finger-tip release.

"GIRDER PROTECTION"

ALL THE WAY AROUND

Hudson cradles you within the new all-steel Monobilt body-and-frame. You get a new kind of protection. Box-steel girders, welded into a solid unit, encircle passenger compartments . . . front, sides and rear! You ride inside a protecting framework. Monobilt body-and-frame furnishes a rigidity, a stability impossible in other kinds of automobile construction.

Monobilt construction gives you a car that really "hugs" the highway! A full 77 inches wide and only 60 inches high, the new Hudson has a center of gravity lower than other mass-produced cars.



CAR MADE SAFER!

HUDSON LETS YOU SEE MORE!

73% MORE VISION!

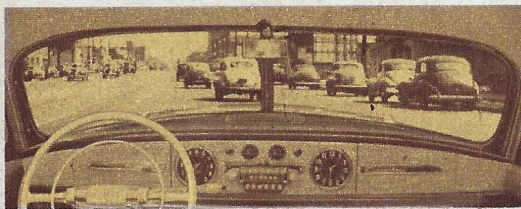

New wider windshield—There's new safety for you in Hudson's full, unhampered vision—with one of the widest windshields ever built—54½ inches from side to side. Gentle curve sweeps rearward, giving a 97½° arc of vision and reducing reflections for easier driving.



Bigger rear window—Hudson's 558-square-inch rear window in all models enables you to keep a watchful eye on traffic behind you and cars about to pass. The curve follows body contour . . . full 36¼ inches wide.

Step into one of these new streamlined beauties with its sweeping full-curved windshield and you'll be immediately aware of the practical increase in vision, the fine new ease

you see more *where you want* a better view. Hudson's new "wide-angle" vision gives you a total visual glass area, in sedans, of 2,500 square inches. Safety glass all around!

More windshield from side to side—Windshield vision from side to side . . . where vision really counts . . . has been increased 14%. No need to sit on the edge of your seat to keep your eye on crossings ahead!

More side vision—You'll find keeping an eye on the traffic alongside you, or watching road signs, is easier with Hudson's side vision, increased 4%.

Rear seat passengers see more, too!—Passengers can enjoy a total of 55% more view in every direction, up and down and toward the front or rear.

with which you can scan the road ahead or spot traffic on either side! And you'll find Hudson's new "wide-angle" vision gives you more than a mere increase in glass area . . . it lets

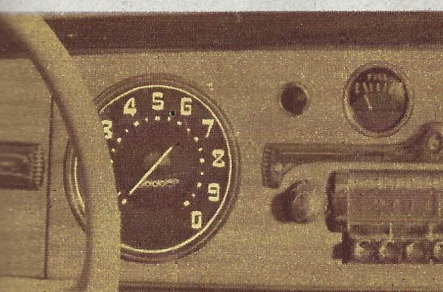
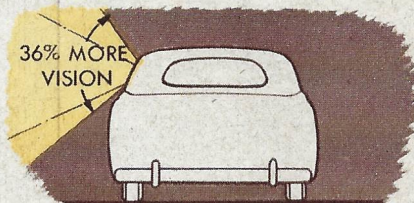
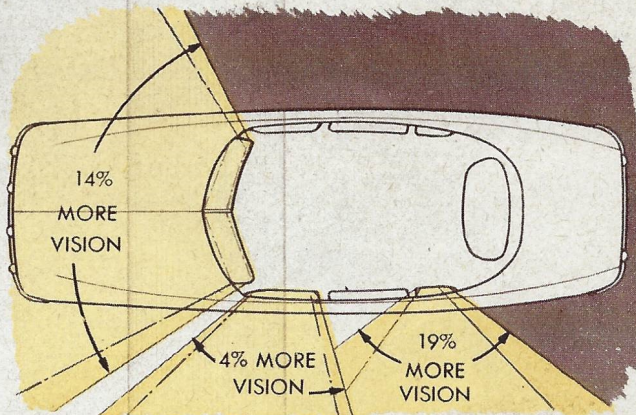

No glare at night—Figures on instrument panel dials are made of extruded light-carrying plastic. Figures and red instrument needles light up, leaving rest of dial dark.

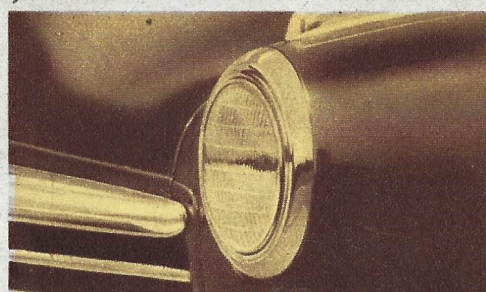

Sealed beam headlights—Flood the road ahead with brilliant light. Headlights stay bright for years because filament and reflector are completely sealed against weather and moisture.

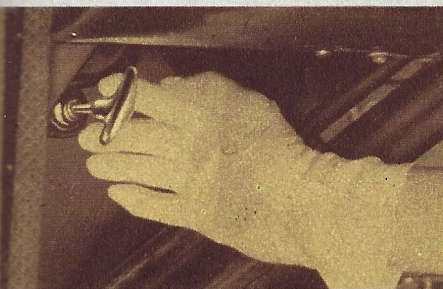

Safety locking hood—For extra protection against theft and accident. Hudson's safety locking hood locks automatically when closed, made doubly secure by positive locking lever located in driver compartment.

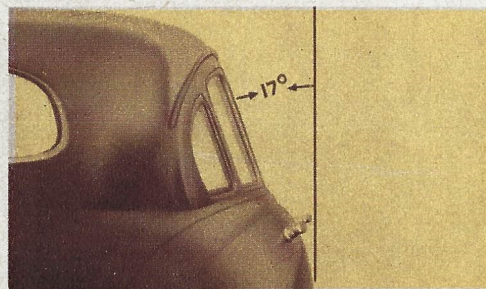

Reduced window reflections—Side windows are inclined at a 17° angle. From a seat position next to the Sedan window, you get a 102° vertical and 123° horizontal field of vision, and annoying reflections are reduced to a minimum.

ADDITIONAL SAFETY FEATURES

- Wrap-around bumpers protect from parking bumps
- Non-rotating, full-rounded door handles, fastened to panel at both ends. No open hooks to catch clothing or fingers
- Recessed door and window controls inside car . . . no sharp projections on instrument panel
- Instrument panel top surfaces finished in special no-glare lacquer to reduce reflections
- Safety-type glass all around
- Directional signals available for all models as optional equipment
- Safety starter cannot be operated with ignition off
- Headlight bright beam indicator in speedometer on instrument panel
- Jack pads, for use with tire jack, on foundation frame member

LUXURIOUS RIDING that

BEST SPRING COMBINATION FOR COMFORTABLE RIDING

The minute you're under way, you know there's something different, something pleasantly exciting about riding in a new Hudson.

Rough country byways, "washboard" pavement, or super-highway—you fairly float along, thanks to the

combination of independent soft-acting coil springs in front, and long, leaf springs in back . . . and Super-Cushion tires on all models, the new high volume, low-pressure tires that give the unique combination of easy riding and easy steering.

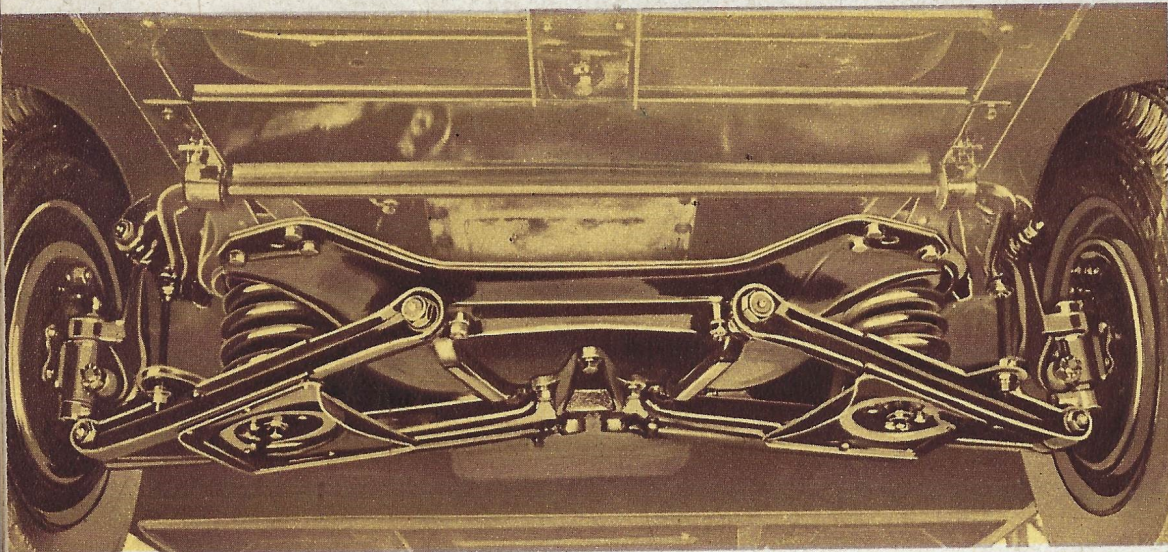

INDEPENDENT FRONT WHEEL COIL SPRINGING

Hudson's independent front wheel suspension is of a type formerly found only in far more costly cars. It provides exceptional flexibility in action . . . a smooth, soft ride under varying road conditions.

Hudson's coil springs are made of specially selected Silico Manganese steel . . . expressly created for spring use. The result: softer, slower action—easier riding.

LONG, LEAF SPRING IN "SPLAYED" POSITION

Hudson's rear springs are mounted in splayed position at a scientifically selected angle with foundation frame for stability.

Hudson rear springs are metal covered for improved lubrication and protection against dirt and weather; fastened to the axle at center for full and equal action.

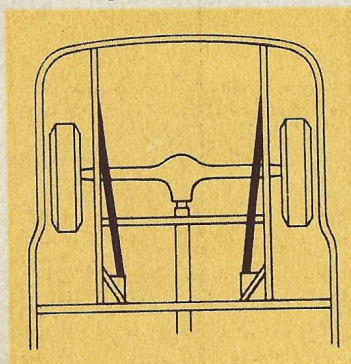
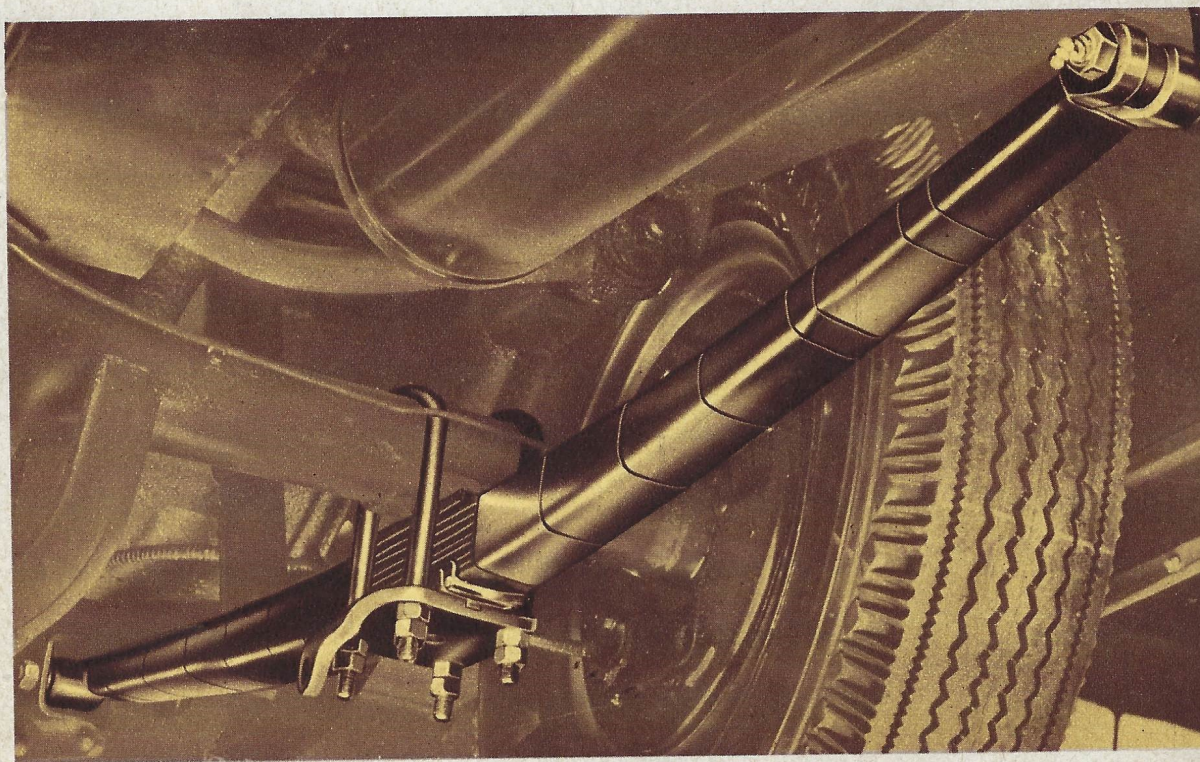

makes rough stretches level out!

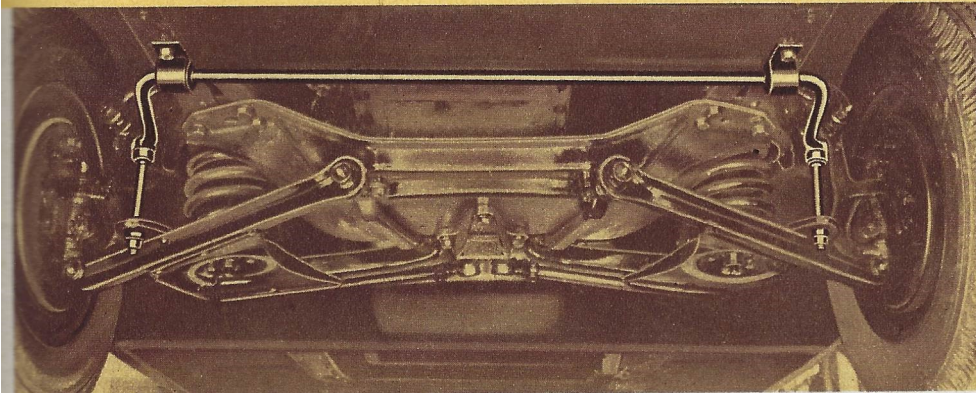

Front stabilizer is rubber-cushion mounted . . . specially designed for operation with Hudson's independent coil springing . . . effectively resists side-sway.

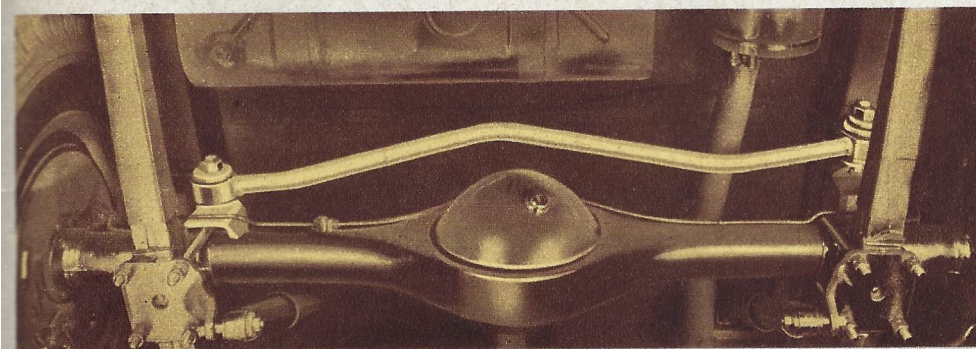

Rear stabilizer bar is rubber-cushion mounted on body-and-frame foundation member at top and on axle housing at bottom.

STEADY ON CURVES AND TURNS

The first curve will tell you about the rigidity and stability of the new Hudson. It "hugs the road" like nothing you've known before. This car is wider than high—the center of gravity is extremely low. This plus splayed springs, and front and rear stabilizers give steadiness on curves unmatched by any other car.

Each stabilizer bar, shown at left, has been designed to do its particular job. Distribution of car weight, type of springing, and center of gravity have all been considered in obtaining maximum efficiency. Hudson's spring suspension and ride control mechanism are a carefully integrated and balanced combination.

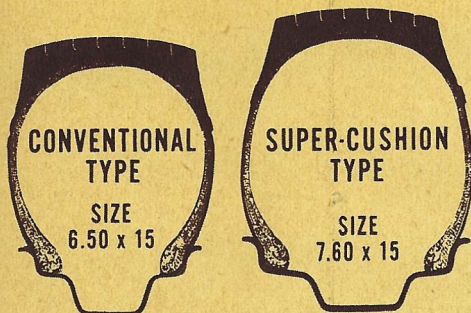

SUPER CUSHION TIRES WITH WIDE SAFETY RIMS

These new "cushion" tires seem to float over road irregularities, gently cushioning you and your passengers with a luxurious new ride. Larger and softer, with 14% less air pressure (only 24 pounds), they absorb road impacts instead of resisting them. A slightly narrower tread gives you easier steering, and a combination of slotted tread, lower air pressure and more flexible construction gives better traction and safer car handling. Super-Cushion tires are standard on every new Hudson.

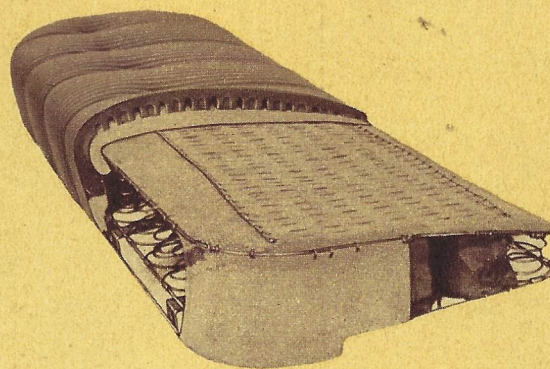

AIRFOAM CUSHIONS

Sink down on Hudson's Airfoam seat cushions. These luxurious cushions are almost unbelievably soft, contain thousands of tiny air cells that cradle your weight. Made of Latex, Airfoam cushions outwear ordinary cushions by years.

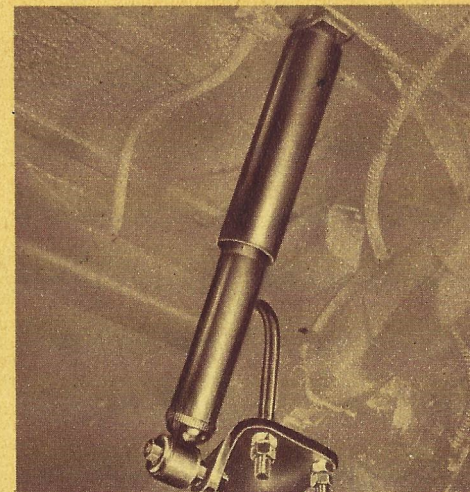

DIRECT-ACTING SHOCK ABSORBER

Direct-acting shock absorbers, to control spring action, both front and rear, complete Hudson's super-soft ride. These direct-acting, large-volume shock absorbers hold more cushioning fluid than elbow types.

HOW MOTORING SATISFAC

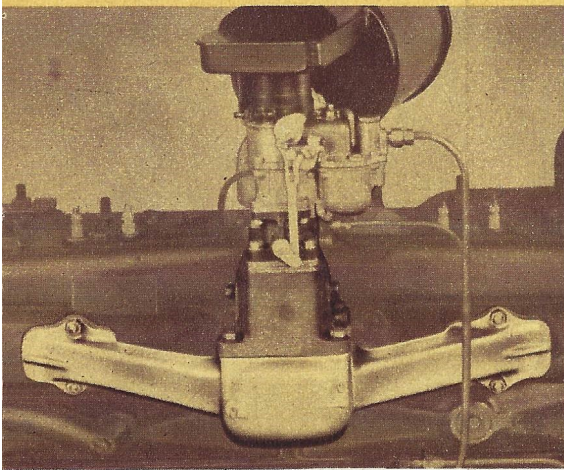

Dual carburetion with more direct passage of fuel from carburetor to cylinders insures fully vaporized mixture equally distributed to all cylinders.

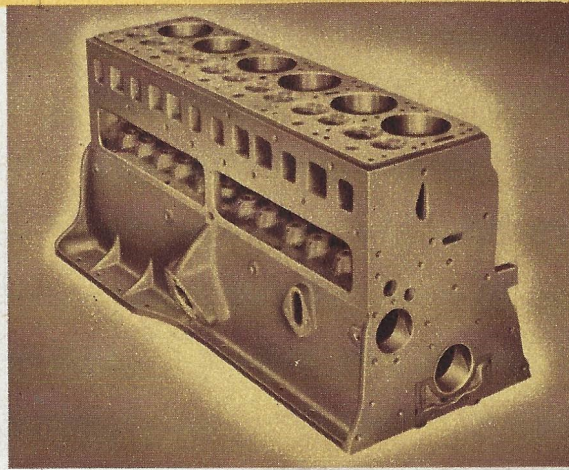

High-chrome-alloy cylinder block so hard it outwears ordinary blocks, machines to super-smooth finish and minimizes wear.

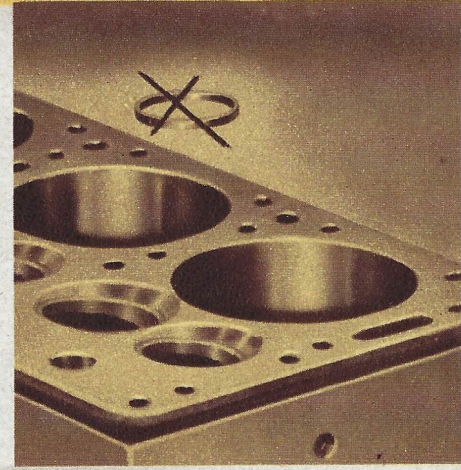

Special valve seat inserts are unnecessary as Hudson's chrome alloy cylinder block is as hard as valve seat inserts used in many cars.

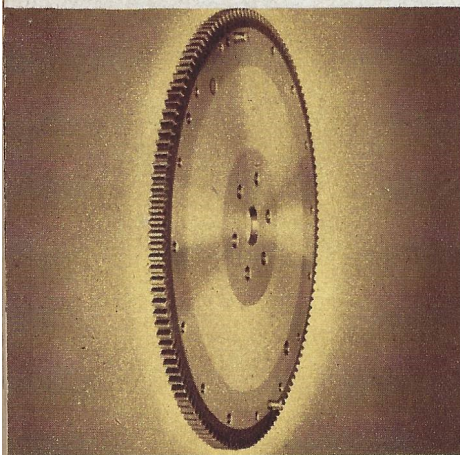

Steel flywheel is lighter and stronger than ordinary cast-iron types, provides best clutch contacting surface.

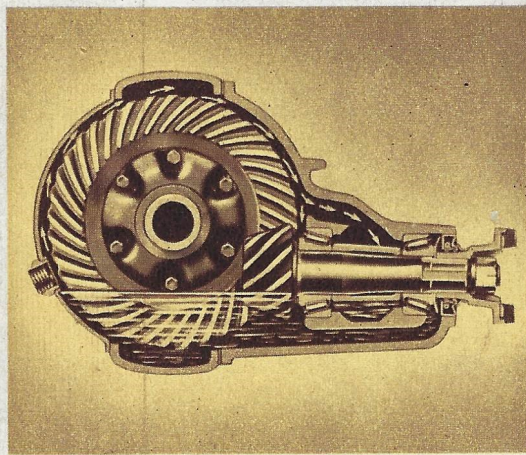

Hypoid axle with nickel-molybdenum alloy drive gears built for long life and quiet operation.

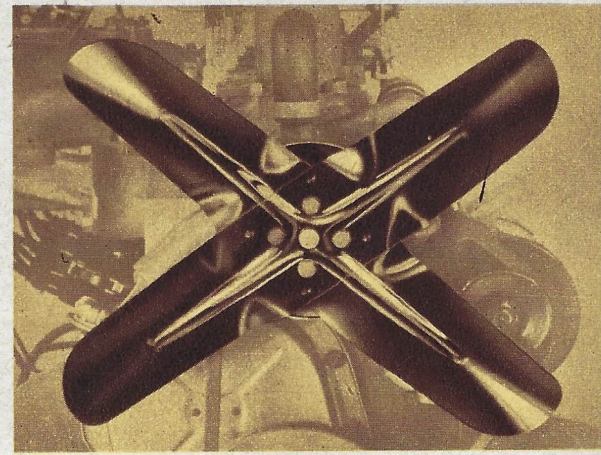

Fan is acoustically designed with specially positioned blades to reduce noise without impairing efficiency. Ball bearing mounted.

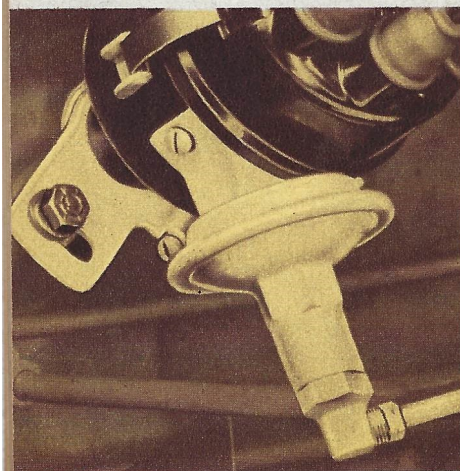

Automatic vacuum spark control retards spark when engine is operating at slow speeds or under heavy loads, providing smoother operation.

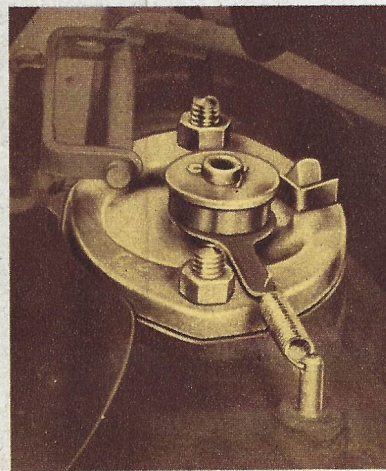

Heat control valve passes exhaust gases over carburetor jacket, pre-heating gas mixture for easy starting and fuller combustion.

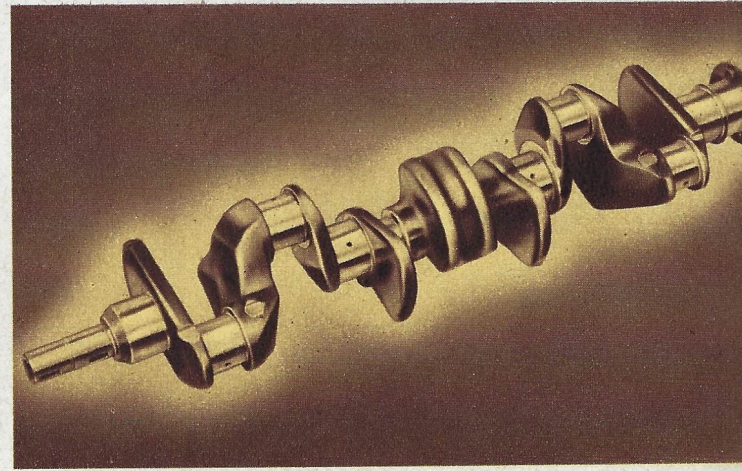

Crankshafts on both Super-six and Super-eight are dynamically and statically balanced for smooth, all-speed operation. Super-six has four main bearings, Super-eight, five.

TION IS BUILT IN...



Hudson-designed spark plugs are ribbed for quicker heat dissipation, longer life and resistance to moisture.

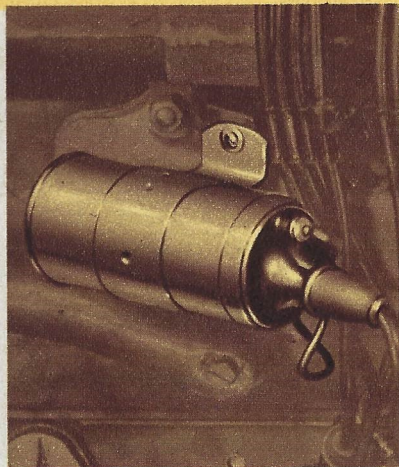

Hudson ignition coils are moisture-proofed, placed close to the distributor. Reduced radio and television interference.

HHEAD A HUDSON into heavy city traffic, into a seldom-used byway . . . or up a tough mountain climb, you'll glow with pleasure at its immediate, sure response to your every command.

Hudson's high horsepower Super-engines are built to give you action, rating at the top in the industry for efficiency . . . for maximum power output for each gallon of gasoline consumed.

The Hudson kind of performance, economy and endurance depends on many mechanical features you seldom have occasion to see. Hudson's outstanding records on all three of these points are proof indeed of the quality and engineering.

Only a few of the carefully engineered and tested Hudson features can be shown here. Many of them are exclusive with Hudson. All are important contributions to your motoring satisfaction.

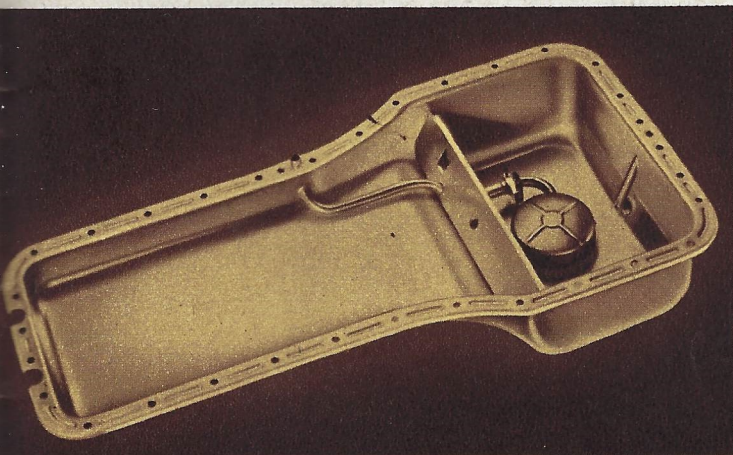

New Hudson oiling system intake draws oil from sump at point beneath surface where neither surface dirt nor bottom sediment can get into system.



Hudson pistons are aluminum alloy, cam ground, T-slot type with pinned rings for performance and economy.

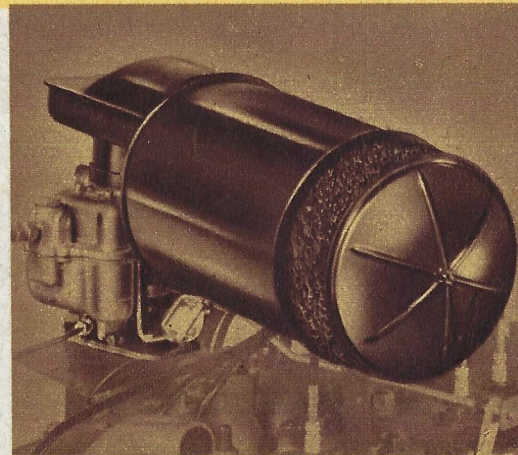

Down draft carburetion is used with large steel mesh air filter. Provides ample supply of clean air to carburetor.

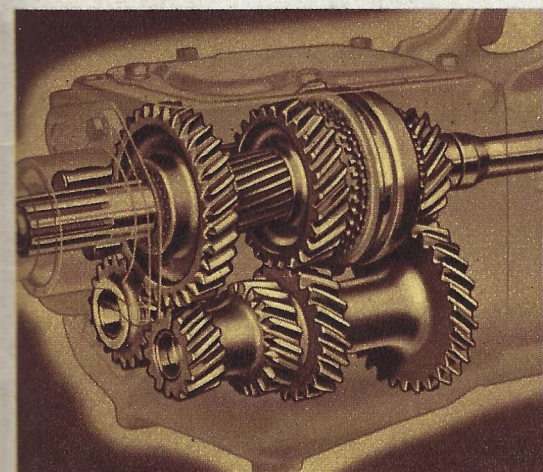

Transmission is synchronized, silent-mesh type with gears specially treated for long life and quiet operation. Easy silent shifting.

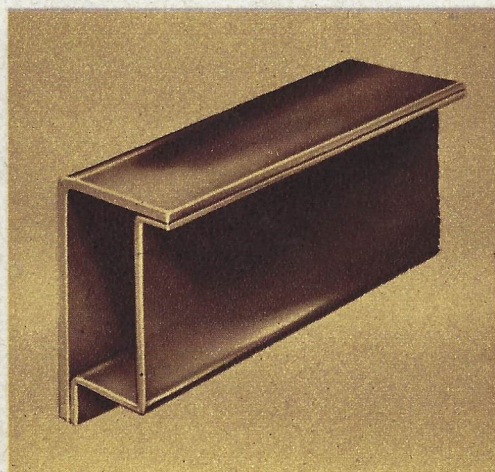

Hudson Monobilt body and frame members are box-section through-out, giving greater strength with lighter weight.

Other important features . . .

- Silver-plated electrical connections
- Rubber-cushioned engine mounts
- Short drive-shafts eliminate whip
- Three needle-bearing universals
- Wheels 15", with super-cushion tires
- Convenient, easily read oil-level dip-stick
- Thermostatic control of water temperature
- Well ventilated crankcase
- Chromodizing rust-proofs all sheet metal

SPECIFICATIONS: TWO GREAT SERIES

CAR SPECIFICATIONS

HUDSON SUPER-SIX AND SUPER-EIGHT

Striped Bedford Cord upholstery . . . "salt and pepper" gray, front floor covering in carpet-like thick rubber . . . rear compartment carpeted . . . cord robe hanger in sedan models . . . dark walnut, wood-grain instrument panel with window garnish mouldings to match . . . 30-hour clock . . . 17" rim steering wheel . . . adjustable sun visors . . . arm rests at ends of all seats . . . latch-type front door ventilating wings . . . wing-type rear quarter windows in sedan . . . side window reveal mouldings . . . full-opening rear quarter windows in 6-passenger coupes . . . front parking lamps . . . standard type twin tail lamps . . . carry-all luggage compartment with provision for spare tire in horizontal position . . . luggage compartment floor mat . . . wheel covers. Optional at small extra cost: Airfoam cushions . . . white sidewall tires . . . bumper guards.

HUDSON COMMODORE SIX AND COMMODORE EIGHT

Broadcloth upholstery, tan with green stripes or gray with blue stripes . . . Airfoam cushions . . . taupe front floor covering of carpet-like thick rubber . . . rear compartment carpeted . . . cloth covered robe hanger in sedan models . . . 16" rear seat center arm rest in sedan and club coupe . . . cigarette lighter . . . instrument panel, two harmonizing shades of natural-finish walnut grain . . . instrument dial dimmer . . . natural-finish walnut-grain window garnish mouldings . . . twin adjustable swivel sun visors . . . 18" plastic-rim de luxe steering wheel with full circle horn ring . . . electric clock . . . side window reveal mouldings . . . crank-type front door ventilating wings . . . wing-type rear quarter window ventilation in sedan . . . full-opening rear quarter windows in 6-passenger coupe models . . . rubber luggage compartment floor mat . . . de luxe twin tail lamps . . . front parking lamps.

GENERAL SPECIFICATIONS

GENERATOR—Extra-capacity, ventilated-type with full voltage regulation on all models.

STARTER—Finger-touch button on instrument panel. New anchor plate type Bendix drive.

FUEL SYSTEM—20-gallon gasoline tank. Large, constant-pressure fuel pump.

COOLING SYSTEM—Cellular-tubular radiator with centrifugal, six-blade pressure pump . . . thermostat on all models . . . temperature indicator on dash. Fan has acoustically positioned blades.

HANDY SHIFT—Standard on all models. Simplified linkage to transmission. Hudson Drive-Master optional at extra cost.

CLUTCH—Balanced, 10" diameter; fluid-cushioned, triple-sealed, single-plate type with heat-treated cork inserts.

BATTERY—Heavy duty 17-plate, 120 ampere-hour. High plate area.

TRANSMISSION—Synchronized Silent Mesh, blocker-type, three speeds forward, one reverse. Helical, silent gears.

UNIVERSALS—Three lubricated needle-bearing universals with 2" tubular propeller shaft.

SPRINGS—(Front) Independent Suspension with coil springs of Silico Manganese steel and direct-acting, high volume, low pressure, hydraulic shock absorbers both front and rear. (Rear) Semi-elliptic, metal covered springs "splayed" for transverse stability; U-type, self-adjusting rear shackle with rubber dirt seal. Front of rear springs rubber mounted. Rear and front stabilizers control lateral car movements.

REAR AXLE—Hypoid, semi-floating, nickel-molybdenum gears and nickel-

chrome-molybdenum axle shafts. Heavy banjo-type housing. Standard ratio, 4-1/10 to 1 on all models; optional ratio, 4-5/9 to 1 or 4-3/10 to 1. With Overdrive, standard ratio is 4-5/9 to 1, with optional ratios of 4-1/10 to 1 or 4-3/10 to 1. Drive-Master, 4-1/10 to 1.

TRIPLE-SAFE BRAKES—Finest hydraulics with reserve mechanical system operating from same brake pedal if ever needed. Finger-tip release parking brake.

WHEELBASE—All models, 124"; overall length, 207½".

STEERING—Center-Point Steering, provides stability at all speeds on all road surfaces, with short turning radius. Improved worm and roller type gear; 20.4 to 1 on all models.

WHEELS—Steel, balanced, drop-center type. New wide base rim for 15" diameter Super-Cushion tires.

TIRES—High volume, low pressure Super-Cushion Tires. Size 15 x 7.10 standard on all models. Optional at extra cost, 15 x 7.60.

VENTILATION—Large cowl ventilator with built-in rain separator unit and insect screen. Draft-free front window ventilation. Hudson Weather-Control for year-round comfort, optional at extra cost.

WINDSHIELD—Extra wide, deep curved design for increased vision, reduced reflection.

LIGHTS—Headlamps: "Sealed Beam" type, incorporating lens, reflector and filaments in a permanently sealed unit. Toe switch for driving or passing beam . . . bright beam indicator on instrument panel. Front parking lights on all models.

Directional signals, front and rear, operated by lever at steering wheel, optional on all models at extra cost. Front dome lamp all models. Courtesy light for all doors, and two rear compartment and dome lamps standard on Commodore models.

EQUIPMENT—Large parcel compartment with lock . . . twin contour-following vacuum windshield wipers . . . rear vision mirror . . . gas-level gauge . . . twin air horns. Teleflash signals for oil pressure and generator charge indicator . . . water temperature gauge . . . windshield defroster vents . . . automatic ejection cigarette lighter standard on Commodore . . . Cushion-Action door latches . . . thiefproof locks . . . non-rotating outside door handles with trigger-operated latch release . . . arm rests at ends of all seats . . . carry-all luggage compartment with provision for spare tire . . . bumper guards on all Commodore models . . . aluminum scuff plates on all models . . . rear compartment carpet, low pile . . . assist straps in Super Series Broughams, Sedans and both Super and Commodore 6-passenger Club Coupes . . . metal hand rails on back of front seat in Commodore Sedans . . . windshield reveal mouldings . . . rear window reveal moulding on Commodore model . . . ash receivers . . . envelope-type pocket in front seat-back of Sedans only . . . rear compartment door ornament.

NOTE: The Hudson Motor Car Company reserves the right to make any changes or improvements on its products without incurring any liability or obligations whatsoever, and without being required to make any corresponding changes or improvements on products theretofore manufactured or sold.

HUDSON-BUILT CARS

HOLD 149 AAA STOCK CAR RECORDS

Hudson-built motor cars hold more official stock-car records than any other make. All were gained in carefully supervised American Automobile Association official contests which Hudson entered not just to make records, but as a

means of making doubly certain that you get performance, safety, economy and endurance when you invest in a Hudson. Hudson performance is proved performance. When you drive a Hudson, you drive a *winner!*

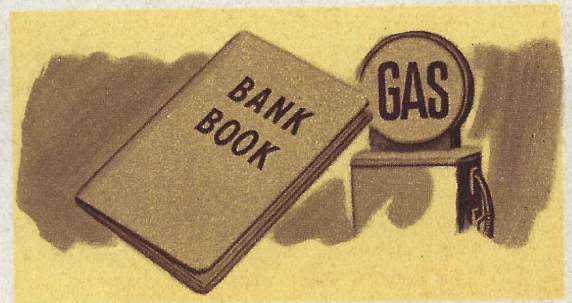

PERFORMANCE

Hudson's "wins" include stock closed-car marks ranging from one kilometer to the famous 24-hour record. This coveted record was won and held in competition open to all stock cars, regardless of size and class.

ENDURANCE

Here's stamina for you . . . twenty thousand miles in less than twelve days . . . average speed over 70 miles per hour! A *stock-car* record set with a Hudson taken right from the factory assembly line.

ECONOMY

Standard model Hudsons, fully equipped and loaded, have been victorious in National Economy Runs, at normal driving speeds and normal driving conditions. Economy competition based on gas and oil consumption.

These official stock-car records made by Hudson-built cars have never been broken! Established under rules and sanction of AAA Contest Board.

13 UNLIMITED CLASS RECORDS for closed stock cars regardless of size and piston displacement! Distances from 3,000 to 20,000 miles and 5,000 to 30,000 kilometers! Including 20,000 non-stop miles at 70.58 electrically timed miles per hour—made by a powerful Hudson Six!

11 UNLIMITED CLASS "PERIOD" RECORDS for closed stock cars regardless of size and displacement. Non-stop runs from 2 to 12 days, including the 12-day record of 20,327.42 miles at an official average speed of 70.58 miles per hour—made by Hudson Six!

6 STANDARD START RECORDS for Class C closed cars (183 to 305 cu. in. displacement) including the 10-mile record of 87.93 miles per hour—made by a famous Hudson Eight.

29 CLASS C DISTANCE RECORDS from 1 to 3,000 kilometers and 1 to 2,000 miles—made by a Hudson Eight which covered the 2,000 miles at an official average of 87.78 miles per hour.

5 CLASS C "PERIOD" RECORDS—1 to 24 hours, including the coveted 24-hour record won by Hudson Eight at 87.68 official miles per hour.

6 STANDING START RECORDS for Class D closed cars (122 to 183 cu. in. displacement) from 1 kilometer to 10 miles, including the 10-mile record of 73.11 miles per hour—set by Hudson Six.

42 FLYING START RECORDS for Class D closed cars, from 1 to 30,000 kilometers and 1 to 20,000 miles—made by a Hudson Six that covered 20,000 miles at an average official speed of 70.58 miles per hour.

16 "PERIOD" RECORDS for Class D closed cars—1 hour to 12 days—held by a Hudson Six that set the one-hour record at 80.54 official miles per hour and the 12-hour record at 70.58 miles per hour.

21 A.A.A. HILL-CLIMB RECORDS—including the famous Mt. Washington, N. H., Wrightwood Canyon, Calif., and Summit Mountain, Pa., runs.

**Your Hudson dealer can show you a complete list of all Hudson official AAA records.*

YOU'LL FIND FRIENDLY HUDSON SERVICE

*Wherever
you travel!*

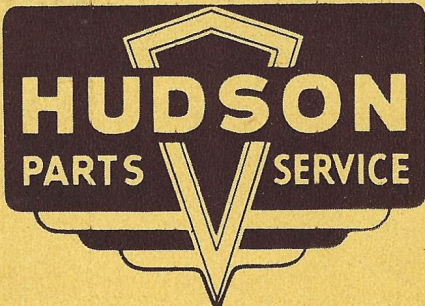

★ = DISTRIBUTORS AND PARTS DEPOTS
• = AUTHORIZED DEALERS

Travel wherever you wish on the North American Continent, or even to the far ends of the earth—or cruise your own neighborhood—you're never far from the red, blue and white sign that identifies more than 3,000 Hudson authorized dealer and distributor service establishments.

Every Hudson dealer maintains a service department that is modernly equipped and provided with a well-balanced stock of genuine Hudson parts. He is further supported by 166 strategically located distributor-operated Parts Depots. Trained service men are ready to help you at all times.

With a Hudson, you need mighty little service, but what little you need, is mighty easy to get.

THIS TIME IT'S HUDSON



HUDSON MOTOR CAR COMPANY • DETROIT 14, MICHIGAN

Exclusive with Hudson

Triple-Safe Brakes!

Hudson provides powerful hydraulic brakes; a feather's pressure brings them into action. "Servo-action" brakes actually convert forward rotation of the wheels into extra braking pressure. A reserve mechanical system is ready to take over automatically from the same pedal if hydraulic pressure should fail, as it might in any car through accident or service neglect. Finger-tip released parking brake has handle conveniently mounted under left side of instrument panel.

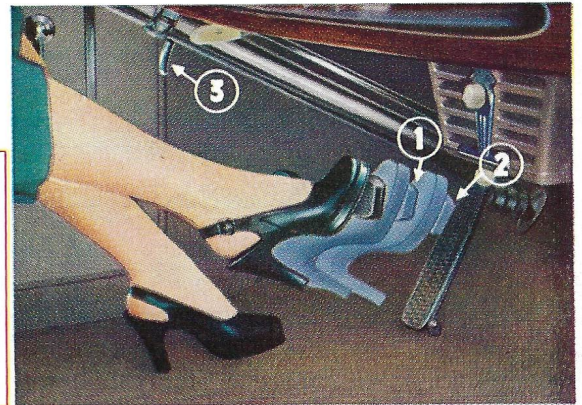

Smooth-Acting Fluid Cushioned Clutch

Hudson's exclusive fluid-cushioned clutch uses special heat-treated cork friction surfaces to give soft contact. Cork contact points, oil impregnated, give sure grip with no metal-to-metal contact. Triple sealed against dirt and weather. Smoother acting and longer lived than dry-plate clutches. This exclusive Hudson clutch costs more to build . . . but less for you to operate.

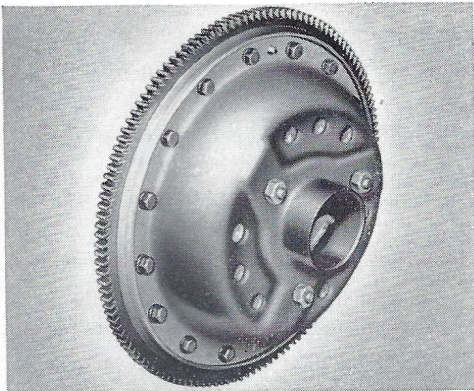

"It's Always Fair Weather" inside your Hudson!

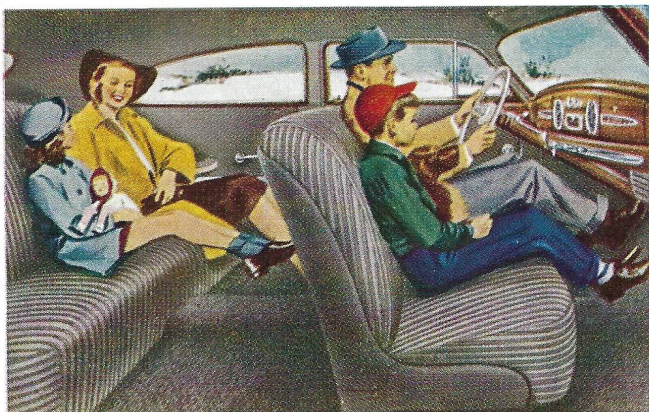

Take winter's worst with a smile. Hudson Weather-Control, available for all models at slight extra cost, takes the sting from the north wind and keeps your car windows and windshield frost free. Your car is filled with warm, fresh air—ankle-chilling drafts are gone. Here, in one compact unit, is a four-fold heating-ventilating-conditioned air-defrosting system. Far more than just a heater.

With Weather-Control, fresh *outside* air flows in through the cowl ventilator. A sturdy screen filters out dust and blocks out insects; a specially designed rain-trap drains away water. Car movement forces in plentiful air, and if traffic causes you to stop, a powerful two-speed blower fan is provided to bring in air. In summer, flip the control lever to "cooler" and end heating. You still get fresh, outside air.

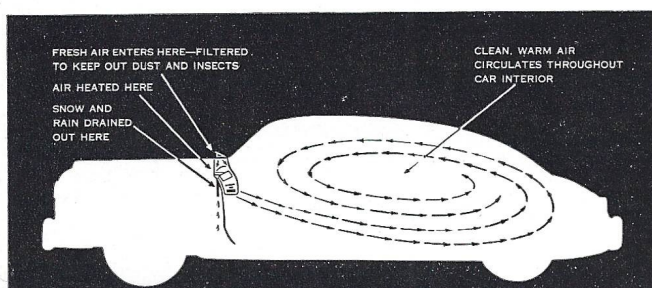

All yours ... but only in Hudson!

TRUE CENTER-POINT STEERING

Acts equally on either wheel; most accurately designed and easy to handle steering system known.

STEEL FLYWHEEL

Hudson's steel flywheel is lighter and stronger than cast-iron types. Requires less power to start.

COIL AND LEAF SPRINGS

Hudson has special silicon steel coil springs in front and long, leaf springs (mounted in splayed position) in rear.

TRIPLE-SAFE BRAKES

Finest hydraulics, plus mechanical reserve system operating from same brake pedal; finger-tip released parking brake.

SYNCHRONIZED SILENT TRANSMISSION

Synchronized silent transmission has been specially designed to operate with Hudson's handy shift lever.

FULLY BALANCED CRANKSHAFT

Crankshaft fully compensated. Drop-forged with integral counterweights. Statically and dynamically balanced.

HIGH CHROME ALLOY ENGINE BLOCK

Entire engine block is made of high chrome alloy, eliminates need for valve seat inserts, outwears softer blocks.

DUAL CARBURETION

Dual carburetion gives more equal distribution of fuel mixture to all cylinders for maximum performance.



HUDSON MOTOR CAR COMPANY

DETROIT 14, MICHIGAN

MONROE & FRANKSON

HUDSON SALES and SERVICE

822 SO. SAN FERNANDO BLVD. - CH 6-1201

BURBANK

FRIENDLY HUDSON DEALERS...

wherever you go!

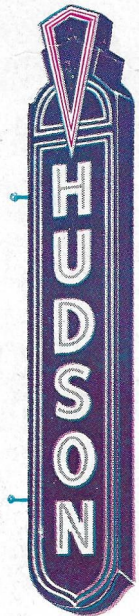

Travel wherever you wish on the North American Continent, or to the far ends of the earth, or cruise your own neighborhood, and you're never far from the red, blue and white sign that identifies more than 3,000 Hudson dealer and distributor establishments.

Every Hudson dealer maintains a service department that is modernly equipped, and provided with a balanced stock of genuine Hudson parts. He is further supported by 166 strategically located, distributor-operated Parts Depots. Service men are ready to help you at all times and are especially skilled in the kind of preventive maintenance that keeps your car new long after "delivery" day. With a Hudson, you need mighty little service, but what little you need is mighty easy to get!

THIS TIME IT'S HUDSON