

Short to Long Wheel base Twin H linkage comparison



Short Wheelbase Hudson Twin H linkage
note the center connection for throttle pedal linkage



Short Wheelbase Hudson Twin H linkage



Twin H on 54 Super Wasp (262 engine)

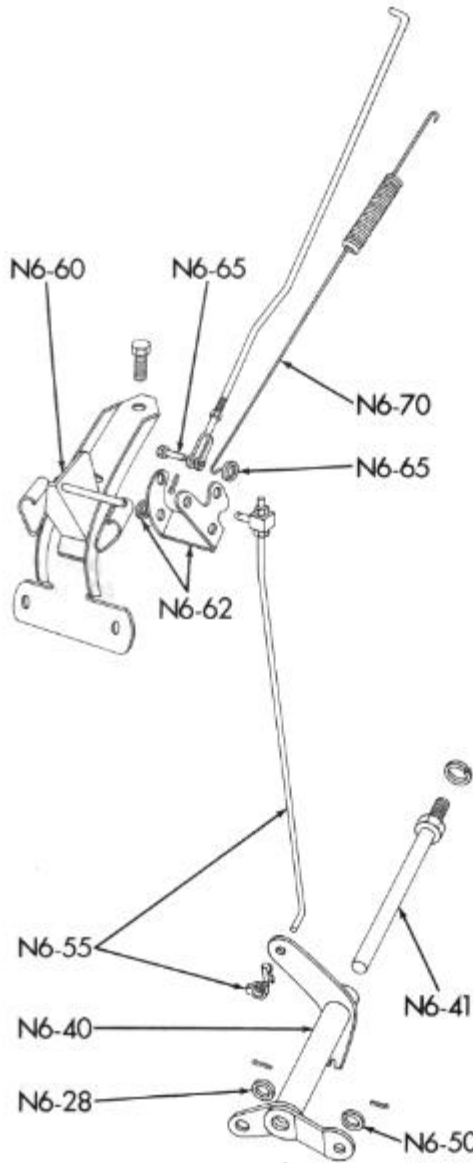

TYPICAL "232" ENGINE

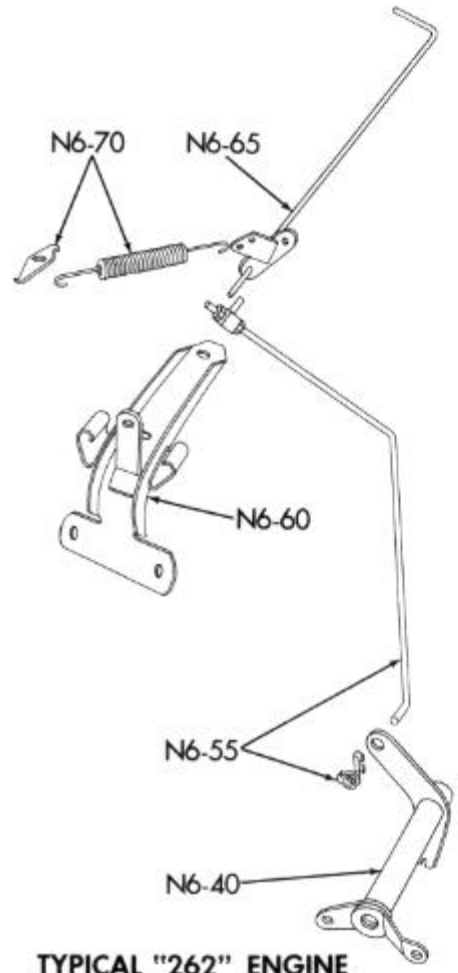

**TYPICAL "262" ENGINE
PACEMAKER AND WASP**

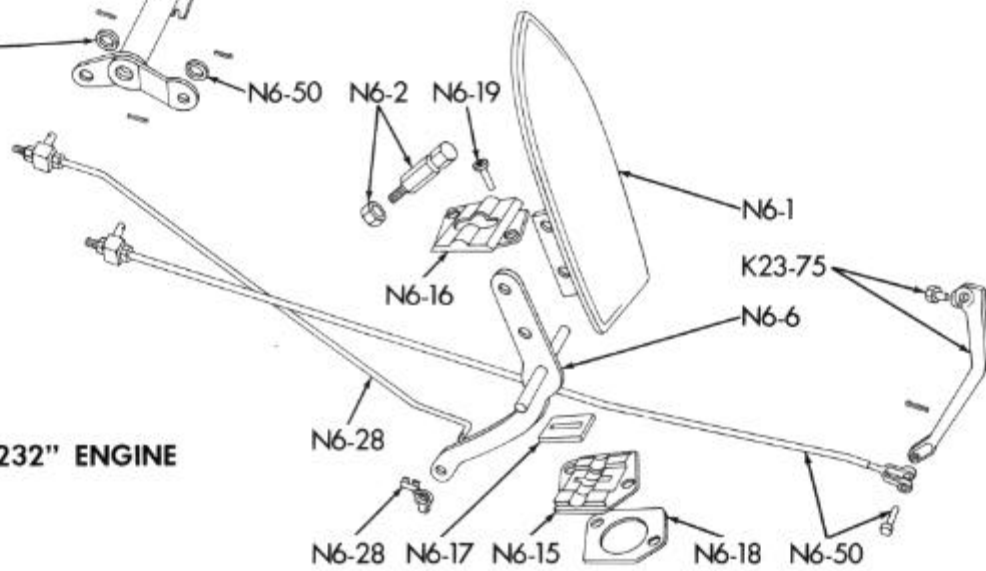

TYPICAL "232" ENGINE

THROTTLE CONTROL

Short to Long Wheel base Twin H linkage comparison



Long Wheelbase Twin H linkage

Note the throttle pedal linkage connects to the right end of the linkage rod



Long Wheelbase Twin H linkage



Long Wheelbase Twin H linkage



Long Wheelbase Twin H linkage

Installed on a Hornet motor